

Sunny Boy 700U

Photovoltaic, Grid-Tied
String Inverter



Installation Guide

Copyright © 2003 SMA America, Inc. All rights reserved.

No part of this document may be reproduced, stored in a retrieval system, or transmitted, in any form or by any means, electronic, mechanical, photographic, magnetic, or otherwise, without the prior written permission of SMA America, Inc.

SMA America makes no representations, express or implied, with respect to this documentation or any of the equipment and/or software it may describe, including (with no limitation) any implied warranties of utility, merchantability, or fitness for any particular purpose. All such warranties are expressly disclaimed. Neither SMA America nor its distributors or dealers shall be liable for any indirect, incidental, or consequential damages under any circumstances.

(The exclusion of implied warranties may not apply in all cases under some statutes, and thus the above exclusion may not apply.)

Specifications are subject to change without notice. Every attempt has been made to make this document complete, accurate, and up-to-date. Readers are cautioned, however, that SMA America reserves the right to make changes without notice and shall not be responsible for any damages, including indirect, incidental or consequential damages, caused by reliance on the material presented, including, but not limited to, omissions, typographical errors, arithmetical errors, or listing errors in the content material.

Revision History

Rev. No.	Date	By	Reason
0.1	Sept. 2, 2003	Mike Brazil	Alpha draft
0.2	Oct. 16, 2003	Mike Brazil	Beta draft
0.3	Nov. 12, 2003	Jeffrey Philpott	Preliminary Release
1.0	March 22, 2004	Gerald Salisbury	First official version

SMA America, Incorporated
12438-C Loma Rica Drive
Grass Valley, California 95945
Tel 530.273.4895
Fax 530.274.7271
www.sma-america.com

IMPORTANT SAFETY INSTRUCTIONS

SAVE THESE INSTRUCTIONS

This manual contains important instructions for the Sunny Boy 700U that must be followed during installation and maintenance of the inverter.

The Sunny Boy is designed and tested according to international safety requirements, but as with all electrical and electronic equipment, certain precautions must be observed when installing and/or operating the Sunny Boy. To reduce the risk of personal injury and to ensure the safe installation and operation of the Sunny Boy, you must carefully read and follow all instructions, cautions, and warnings in this *Installation Guide*.

Safety and Hazard Symbols



This symbol is used to call attention to important information that you must have when installing and/or operating the Sunny Boy. Failure to read and follow instructions marked with this symbol could result in injury or death and/or damage to the equipment.



This symbol appears beside instructions and warnings that deal with dangerous voltages that can injure or kill people who come in contact with them.



This symbol appears beside instructions and cautions that deal with equipment components that can be damaged by static electricity.



This symbol appears beside instructions, cautions, and warnings that deal with portions of the equipment that can operate at temperatures high enough to cause burns.



This symbol appears beside instructions, cautions, and warnings that deal with portions of the equipment that can operate at temperatures high enough to start a fire.

Cautions and Warnings



WARNING: A Warning describes a hazard to personnel. It calls attention to a procedure or practice, which, if not correctly performed or adhered to, could result in personal injury.



CAUTION: A Caution describes a hazard to equipment. It calls attention to an operating procedure or practice, which, if not correctly performed or adhered to, could result in damage to or destruction of part or all of the SMA equipment and/or other equipment connected to the SMA equipment.

Warnings and Cautions may also be accompanied by one or more of the safety and hazard symbols described above to indicate the type of hazard described therein.



All electrical installations must be done in accordance with the local and National Electrical Code ANSI/NFPA 70.



The Sunny Boy contains no user-serviceable parts. Always return the unit to an SMA authorized Service Center for repairs and maintenance.



Before installing or using the Sunny Boy, read all of the instructions, cautions, and warnings on the Sunny Boy, the PV array, and in this Installation Guide.



You *must not* connect the Sunny Boy to the electrical utility grid until you have received prior approval from the utility company. This connection must be made only by qualified personnel.



PV arrays produce electrical energy when exposed to light and thus can create an electrical shock hazard. Completely cover the surface of all PV-arrays with opaque (dark) material before wiring them.



The Sunny Boy has a heat sink on its top surface to help cool the internal components. This heat sink can reach temperatures as high as 158° F (70° C). To avoid the risk of burns, never touch the Sunny Boy's heat sink while the unit is in operation.

Other Symbols

In addition to the safety and hazard symbols described on the previous pages, the following two symbols are also used in this *Installation Guide*:



Note: This symbol accompanies notes that call attention to supplementary information that you should know and use to ensure optimal operation of the system.



Example: This symbol accompanies examples that are included to help you understand certain topics.

Warranty

All Sunny Boy inverters sold in the USA have a five-year warranty, as indicated on the warranty card included in the Sunny Boy shipping container. For warranty coverage, or if you have questions about the Sunny Boy warranty, contact SMA America at the address, telephone number, or Web site listed on page i (to send E-mail, see the Contact section of the SMA America Web site).

Contents

Revision History	i
Safety and Hazard Symbols	ii
Cautions and Warnings	1-iii
Other Symbols	1-iv
Warranty	iv

1 Introduction

Product Overview	1-1
Installation Overview	1-2

2 Unpacking and Inspection

3 Mounting the Sunny Boy

Choosing a Mounting Location	3-1
Dimensions and Recommended Clearances	3-3
Mounting Procedure	3-5

4 Wiring and Connecting the Sunny Boy

Sunny Boy 700U Internal Components	4-2
Opening the Sunny Boy 700U	4-2
Locating Internal Components	4-2
Wiring the AC Output	4-5
AC Connection Requirements	4-5
Connecting the AC Wires	4-6
Wiring the DC Input	4-9
DC Connection Requirements	4-9
Configuring the DC Input-Voltage Range	4-10
Connecting the DC Wires	4-14
Connecting Communication Cables	4-17
RS-232 Communication	4-17
RS-485 Communication	4-19
Replacing the Cover	4-21

5 Commissioning the Sunny Boy

6 Displays and Messages

Fault Indicators	6-6
Communication Options	6-12

Status Messages on the Display. 6-13

7 Troubleshooting

Section 1: Introduction

This installation guide provides all the information needed to mount, wire, and commission a Sunny Boy 700U grid-tied photovoltaic (PV) inverter.



Note: To help avoid problems during the installation, familiarize yourself with the installation process by reading the entire *Installation Guide* before starting the installation.



WARNING: Lethal voltages are present at various points in a PV system. For safety reasons, it is recommended that only trained professionals attempt to install this equipment.

Product Overview

The SMA Sunny Boy 700U string inverter is designed for use in grid-tied PV generating plants. It accepts DC voltage inputs from PV arrays in one of three optional voltage ranges: 125-250 V DC, 100-200 V DC, and 75-150 V DC (an internal jumper must be set for the appropriate voltage range).

A grid-feeding inverter takes the DC output of the PV array, converts it to AC, adjusts the output voltage to match the local utility-grid voltage, and feeds the AC output to both the house wiring and the utility grid. In its most basic form, a PV system therefore consists of three basic components: the PV module (or array of panels), the inverter, and the utility grid. The AC voltage supplied by the PV system is used first by household devices (appliances, lights, etc.), and any unconsumed power is then fed through the house's power meter into the utility grid as shown in Figure 1-1 (page 1-1).

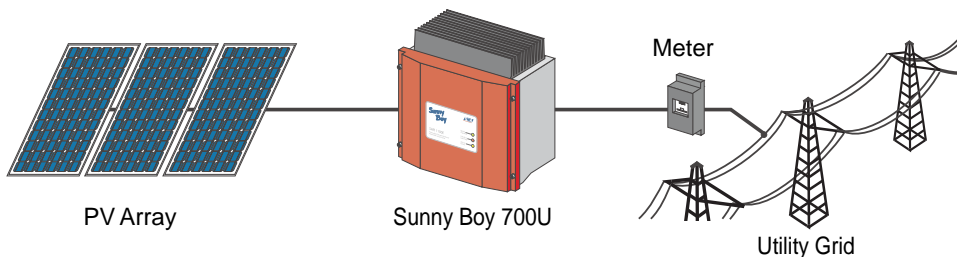

Figure 1-1 Sunny Boy 700U Installed in a Utility Interactive PV System

When the PV system is not producing enough power to meet the demands of all the electrical loads in the household, additional power is drawn from the utility grid to make up the difference. When the PV system is producing more power than is consumed by household devices, the surplus power turns the house's power meter backwards as it passes into the utility grid to be used by other electrical consumers, thus producing utility credits for the power added to the utility grid.



Note: Policies vary from one utility company to another. Consult with a representative of the local utility company before planning and installing a PV system.

Installation Overview

This section provides a high-level overview of the installation process so you have an idea what to expect as you proceed through the rest of the *Installation Guide*.

The installation process is broken down into the following tasks:

Section 2: Unpacking and Inspection

This section provides instructions and information for unpacking the Sunny Boy, inspecting it for shipping damage, and if necessary, returning a damaged Sunny Boy.

Section 3: Mounting the Sunny Boy

This section includes guidelines to help you select the best mounting location, cautions and warnings that you should follow to avoid injury and/or equipment damage, and step-by-step instructions for mounting a Sunny Boy 700U inverter.

Section 4: Wiring and Connecting the Sunny Boy

This section includes guidelines for selecting the correct wire sizes, cautions and warnings that you should follow to avoid injury and/or equipment damage, and step-by-step instructions for setting the internal voltage-range jumper, wiring a Sunny Boy to a PV array, household electrical circuits, and the utility grid. Procedures are also included for connecting optional data-communication cables to the Sunny Boy.

Section 5: Commissioning the Sunny Boy

Commissioning involves applying DC input power to the Sunny Boy, observing the LED indicators on the cover, and resolving any problems that occur.

Section 6: Displays and Messages

This section provides tips and procedures for resolving problems that can occur during installation.

Section 2: Unpacking and Inspection

All Sunny Boy inverters are thoroughly checked before they are packed and shipped. Although they are shipped in sturdy, recyclable packaging, damage can still occur during shipping and delivery. It is important for you to carefully inspect the shipping container prior to beginning the installation. If you detect any external damage to the packaging that makes you suspect the inverter itself could be damaged, or if you find that the inverter is damaged after unpacking it, report the damage immediately to your SMA dealer and to the shipping company that delivered the Sunny Boy. If it becomes necessary to return the Sunny Boy, use the original packaging in which the Sunny Boy was delivered.



WARNING: The Sunny Boy 700U weighs 16 kg (36 lb.). To avoid injury, lift the Sunny Boy carefully, and be careful to prevent the weight of the inverter from causing you to lose your balance and fall. If possible, have someone help you when you unpack the Sunny Boy.

If you need assistance in dealing with a damaged Sunny Boy, contact your SMA dealer or SMA America. Contact information for SMA America is provided below.

SMA America, Incorporated
12438-C Loma Rica Drive
Grass Valley, California 95945
Tel 530.273.4895
Fax 530.274.7271
www.sma-america.com

Section 3:

Mounting the Sunny Boy

This section provides guidelines to help you select the best mounting location, cautions and warnings that you should follow to avoid injury and/or equipment damage, and step-by-step instructions for mounting a Sunny Boy 700U inverter.



WARNING: To avoid injury, lift the Sunny Boy carefully, and handle it carefully to prevent the weight of the inverter from causing you to lose your balance and fall. If possible, have someone help you when you mount the Sunny Boy.

Choosing a Mounting Location

Consider the following guidelines, cautions, and warnings when choosing a mounting location for a Sunny Boy inverter:

- The Sunny Boy 700U should be installed in a location where it is not exposed to direct sunlight, since the higher temperature within the unit caused by the sun can result in reduced output from the PV system. When the heatsink on the top of the Sunny Boy is exposed to direct sunlight, the inverter operates in Derate Mode, which reduces the output power of the system to keep the heatsink temperature below 158° F (70° C).
- The inverter must be installed in a location that is inaccessible to children.
- The Sunny Boy emits a slight vibrating noise when operating. This vibration is normal and has no effect on performance, but it can be objectionable if the inverter is mounted on a wall in a living area, on the outside of a wall that is part of a living area, or on certain types of materials, such as thin wood panelling or sheet metal.
- If the inverter is installed outside, it must be mounted vertically or with the top tilted towards the back. To ensure optimum energy yield and ease of operation, mount the inverter vertically and at eye level (see Figure 3-1).

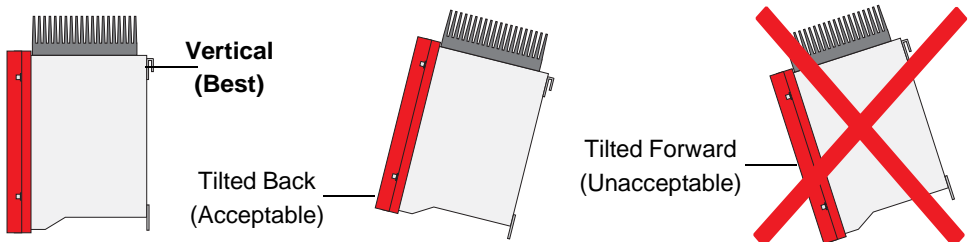

Figure 3-1 Sunny Boy Mounting Positions



CAUTION: The Sunny Boy 700U weighs 16 kg (36 lb.). Ensure that the surface on which you mount the Sunny Boy is strong enough to hold the weight. Do not mount the Sunny Boy on plasterboard (sheet-rock) or thin wood panelling.



CAUTION: All electrical conduits and any communication cables must be positioned and/or sealed so that no water can enter the inverter enclosure through these conduits and cables.



CAUTION: If the Sunny Boy is mounted outside, humid weather during the installation could cause eventual damage to the inverter. If moisture from damp air is enclosed in the case when you complete the installation, it will eventually condense within the case, and the moisture can damage the electronic components. **Do not** install the Sunny Boy when it is raining, and if possible, choose a day when the humidity is low to install it.



CAUTION: If you are installing the Sunny Boy in a cabinet, closet, or other relatively small enclosed area, you must provide sufficient air circulation to dissipate the heat generated by the inverter.



WARNING: When the Sunny Boy is operating, individual parts of the enclosure may reach temperatures of 158° F (70° C). To prevent fires, ensure that nothing comes in contact with the heat sink and that surrounding materials are sufficiently heat-resistant.



WARNING: To prevent electrical shock or other injury, check for existing electrical or plumbing installations in the walls where you plan to drill mounting holes for the Sunny Boy prior to drilling.

Dimensions and Recommended Clearances

The outer dimensions of the Sunny Boy 700U are shown in Figure 3-2. The Sunny Boy must be mounted so that there is at least eight inches of clearance above the heat sink that is mounted on the top of the inverter.

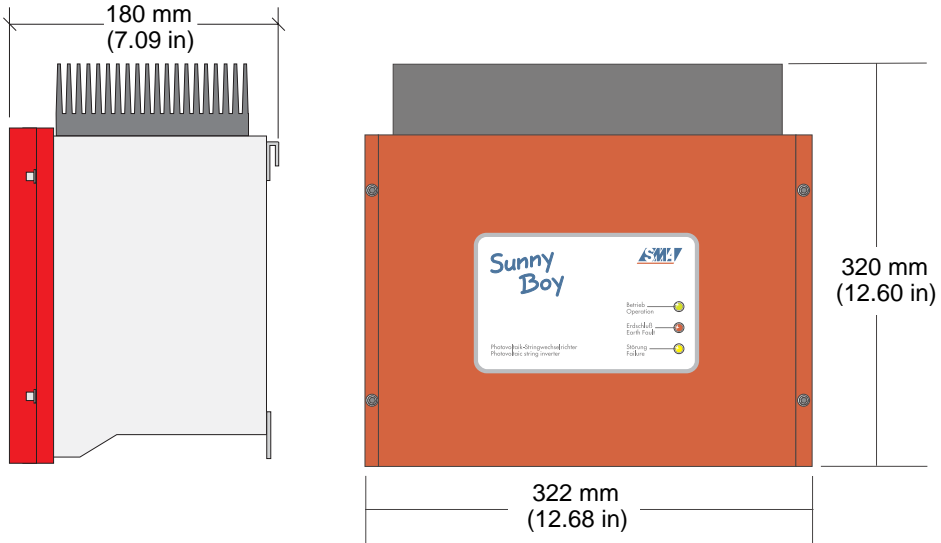

Figure 3-2 Outer Dimensions of the Sunny Boy 700U



CAUTION: You **must** ensure that there is sufficient clearance for heat dissipation above the Sunny Boy's heat sink! In a normal operating environment with good ventilation, eight inches of clearance is adequate. However, if the airflow to the Sunny Boy is restricted or it is subjected to other abnormal operating conditions, enough additional clearance (or forced ventilation) **must** be provided to allow the heat that the Sunny Boy produces to dissipate freely.



Note: If additional ventilation is required use the optional **Sunny Breeze** fan that mounts to the heat sink.



Note: The National Electrical Code may require significantly larger working clearances (see NEC Section 110.26).

Wall-Mounting Bracket

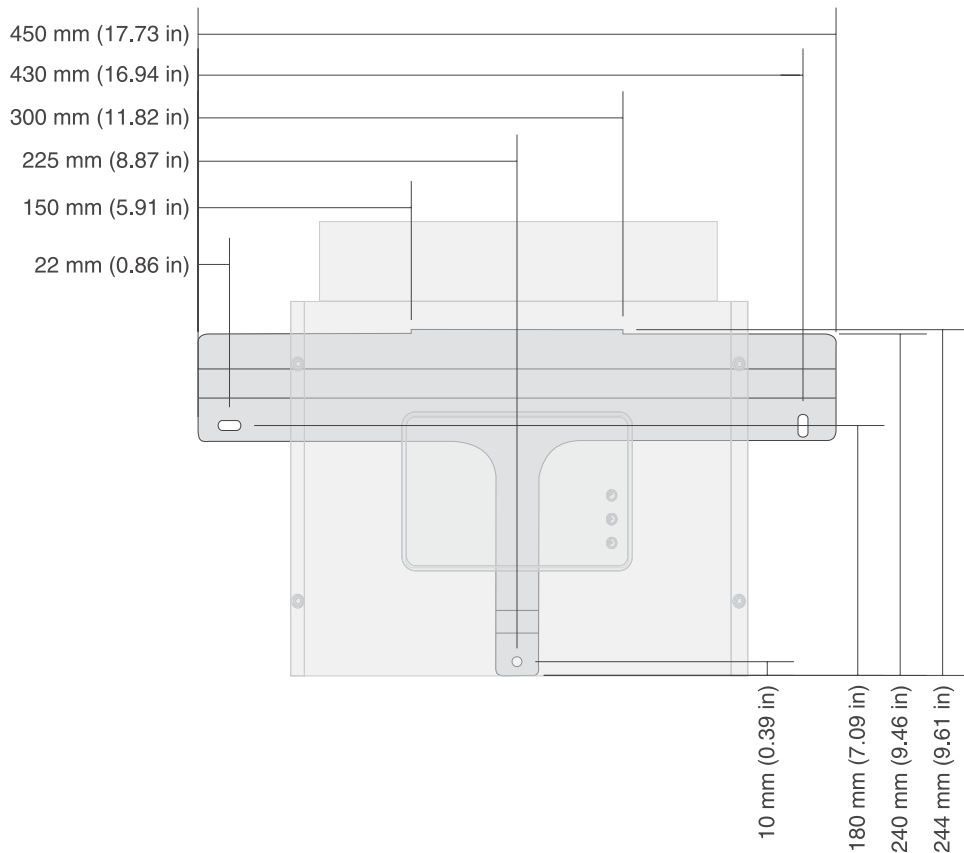

Figure 3-3 Dimensions of the wall-mounting bracket

Mounting Procedure

The Sunny Boy 700U is shipped with a T-shaped wall-mounting bracket that is suitable for use with most walls (see Figure 3-4). The horizontal part of the T bracket has two holes spaced for 16-inch centers for mounting on wooden wall studs, or it can be mounted on concrete or stone walls. Make sure that the wall you choose to mount the Sunny Boy on is sturdy enough to support its weight (16 kg/36 lb.) over a long period of time and that the wall is plumb.

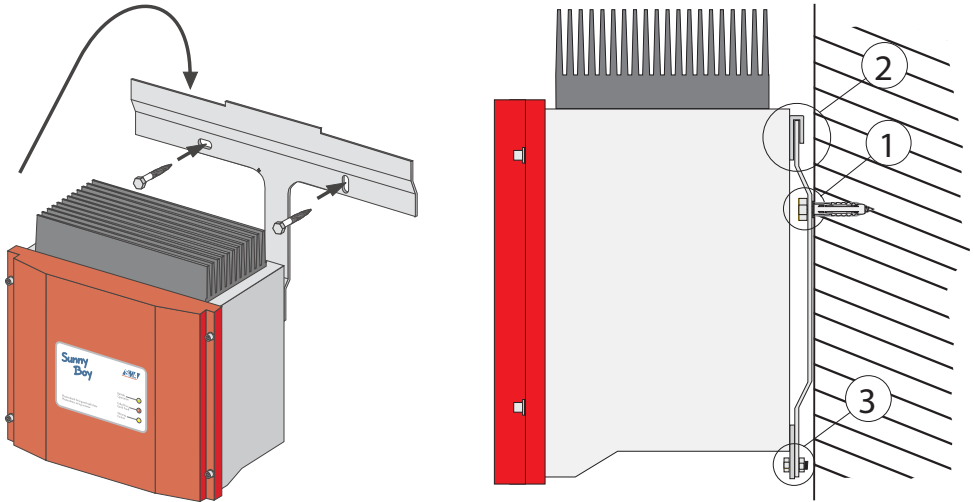

Figure 3-4 Sunny Boy 700U with Mounting Bracket

Use the following procedure to mount the Sunny Boy:

1. Locate the T-shaped wall-mounting bracket included in the shipping container with the Sunny Boy.
2. Position the wall-mounting bracket against the wall where you intend to mount the Sunny Boy (it is best to mount the Sunny Boy at approximately eye-level), place a level on the top edge of the bracket, and adjust the position of the bracket so that it is level.
3. Using the wall-mounting bracket as a template, mark the wall through the two holes in the horizontal portion of the bracket.



CAUTION: Ensure that there are studs in the wall at the places where you intend to drill the mounting-holes. **DO NOT** use molly or toggle bolts to mount the Sunny Boy to sheet rock or panelling.

4. Set the bracket aside temporarily, and drill holes at the marks you made on the wall.



Note: The diameter of the holes you drill must match the hardware you are using to mount the Sunny Boy. For example, if you are mounting the Sunny Boy on a concrete wall, the hole diameter should be approximately the same as the outside diameter of the concrete anchors you intend to use. If you are mounting the Sunny Boy on a wall that has wooden studs inside it, the hole diameter should be the correct size for the lag screws you intend to use to mount the bracket. If you are installing the Sunny Boy outside, the lag screws must be made of stainless steel, and the diameter of the screws should closely match the diameter of the holes in the wall-mounting bracket. If you use M6x10 or 1/4" screws, drill 7/32-inch pilot holes.

5. Insert two stainless-steel lag screws through the holes in the horizontal part of the wall-mounting bracket and into the holes you drilled in the wall. Tighten the screws until the bracket is held firmly against the wall (see #1 in Figure 3-4). Do not over-tighten the screws.
6. Carefully lift the Sunny Boy into position near the mounting bracket. The upside-down, U-shaped bracket attached to back of the Sunny Boy at the top edge fits over the top edge of the bracket so that the Sunny Boy hangs from the bracket (see #2 in Figure 3-4).



WARNING: To avoid injury, lift the Sunny Boy carefully, and handle it carefully to prevent the weight of the inverter from causing you to lose your balance and fall. If possible, have someone help you when you mount the Sunny Boy.

7. Inspect the Sunny Boy from both sides to ensure that the U-shaped bracket on the Sunny Boy fully engages the top edge of the mounting bracket and that the Sunny Boy is centered on the bracket.
8. Locate the mounting strap that hangs from the back of the Sunny Boy at the bottom.
9. Insert an M6x10 bolt through the hole in the mounting strap and into the threaded hole in the bottom end of the wall-mounting bracket (see #3 in Figure 3-4).
10. Tighten the bolt fully (do not overtighten).
11. Verify that the Sunny Boy 700U is firmly mounted in place.

Section 4:

Wiring and Connecting the Sunny Boy

This section provides step-by-step procedures and other information required for wiring the Sunny Boy 700U to the PV array, the household circuits, and the utility grid. To accomplish the installation in the safest and most efficient manner, complete the steps in the order that they appear.



WARNING: Before connecting or operating the Sunny Boy, read all of the instructions, cautions, and warnings on the Sunny Boy, the PV array, and in this *Installation Guide*.



WARNING: You must connect the wires that carry the AC voltage from the Sunny Boy to the utility grid and the wires that carry the DC voltage from the PV array to the Sunny Boy in the order described in the procedures in this section. Deviating from these procedures could expose you to hazardous voltages that can cause serious injury and/or death if you come in contact with them.



WARNING: Always turn OFF all breakers and switches in the PV system before connecting any wires to the Sunny Boy or disconnecting any wires from the Sunny Boy.

WARNING: When connecting wires to the Sunny Boy, always do so in the following sequence:



1. De-energize all AC and DC sources by switching all AC and DC disconnects and/or breakers OFF.
2. Connect the Sunny Boy to the utility grid (using an approved disconnect).
3. Connect the PV wires to the DC disconnect.
4. Connect the DC disconnect wires to the Sunny Boy.
5. Turn the AC switches and/or breakers ON.
6. Turn the DC switches and/or breakers ON.

To disconnect the Sunny Boy, first turn OFF all DC disconnects and then all AC disconnects. After the Sunny Boy is de-energized, disconnect the wiring in the reverse order.



WARNING: Always wait a minimum of 5 minutes for the stored potential in the Sunny Boy to discharge completely before opening the enclosure.



WARNING: All electrical installations must be done in accordance with all local electrical codes and the National Electrical Code (NEC), ANSI/NFPA 70.



WARNING: You *must not* connect the Sunny Boy to the electrical utility grid until you have received prior approval from the utility company. This connection must be made only by qualified personnel.

Sunny Boy 700U Internal Components

All of the terminals and connectors for DC input, AC output, and communications are inside the Sunny Boy's case. To gain access to these and other internal components, you must remove the cover.

Opening the Sunny Boy 700U

Remove the four M5 screws and lock washers that attach the cover to the Sunny Boy. Place the cover, screws, and lock washers aside where they will be out of your way while you are connecting wires and cables to the Sunny Boy.



CAUTION: Be careful not to misplace the screws or the lock washers, as all four screws and lock washers are required to ensure that the cover is grounded properly and is fully sealed to the case. Handle the cover carefully, as even minor damage to the cover could result in an inadequate seal between the cover and the case, thus allowing moisture to enter the case and damage the sensitive electronic components.

Locating Internal Components

Figure 4-1 shows the internal components of the Sunny Boy 700U. Refer to this illustration whenever you need to locate a component to complete a step of the installation procedure.

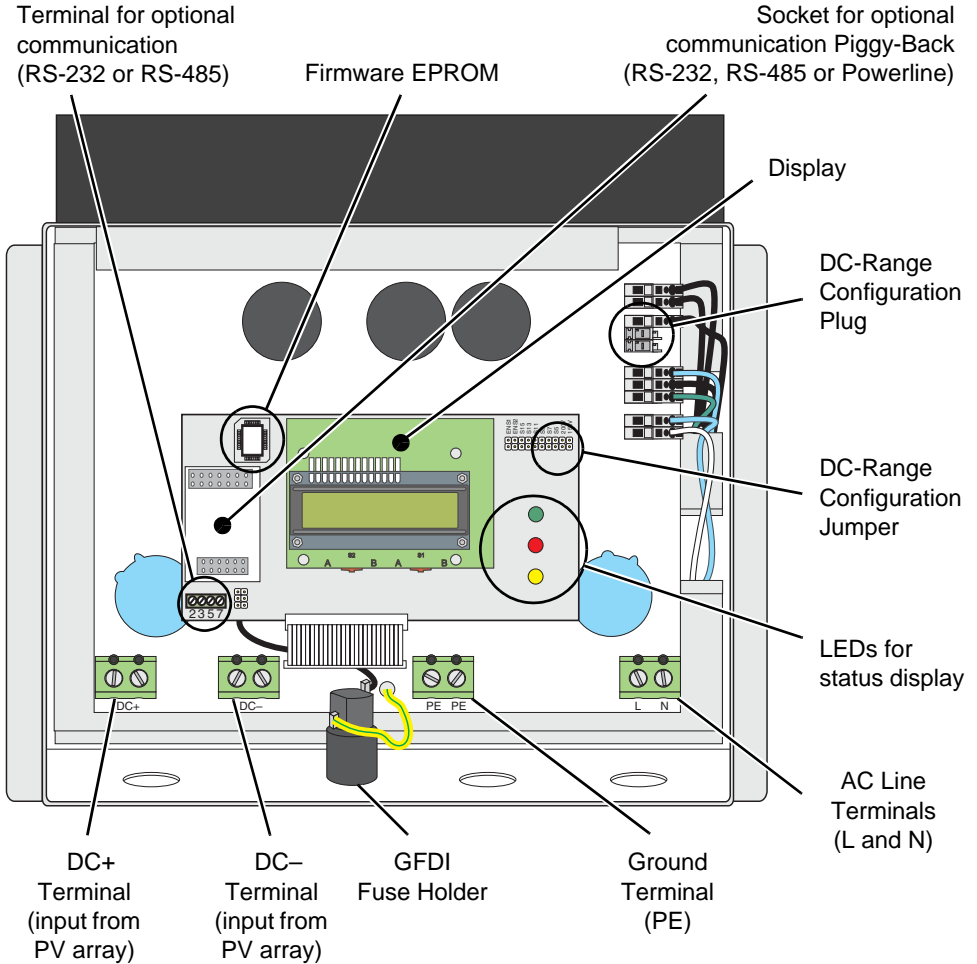

Figure 4-1 Sunny Boy 700U Internal Component Locator

The DC input from the PV array (via the DC disconnect enclosure) and the output to the AC utility grid connect to the inverter inside the Sunny Boy’s case. These internal AC and DC wiring terminals (see Figure 4-1) accept a maximum wire size of #6 AWG. Knockouts are provided on the bottom of the Sunny Boy near each of the terminals for the wires to enter the case (Figure 4-2).

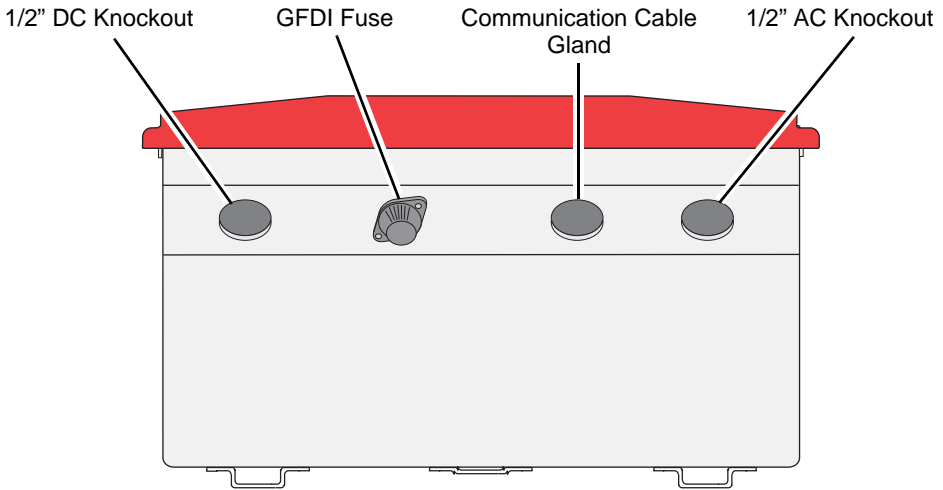

Figure 4-2 Bottom View of the Sunny Boy 700U Showing 1/2" Wiring Knockouts



CAUTION: All knockouts in the Sunny Boy chassis are sized for 1/2-inch rigid conduit (EMT). **DO NOT** enlarge any of these holes, as this is a violation of UL requirements and voids the SMA warranty.

Wiring the AC Output

This subsection provides complete, step-by-step procedures for wiring the AC output from the Sunny Boy to the dedicated circuit and the utility grid.

AC Connection Requirements



WARNING: All electrical installations must be done in accordance with all local electrical codes and with the National Electrical Code (NEC), ANSI/NFPA 70. Use #14 AWG (minimum), 90° C (194° F), copper wire for all AC wiring connections to the Sunny Boy. Voltage drop and other considerations may dictate that larger size wires be used.



WARNING: The National Electrical Code (NEC) states that the inverter must be connected to a dedicated circuit, and that no other outlets or devices can be connected to the same circuit. See NEC Section 690-64(b)(1). The NEC also imposes limitations on the size of the inverter and the manner in which it is connected to the utility grid. See NEC Section 690-64(b)(2).

The diagram in Figure 4-3 shows the potential losses in AC wires with respect to the cross-sectional area of the cable and the length of the cable. Use this table to determine the best wire size to use for your particular installation.

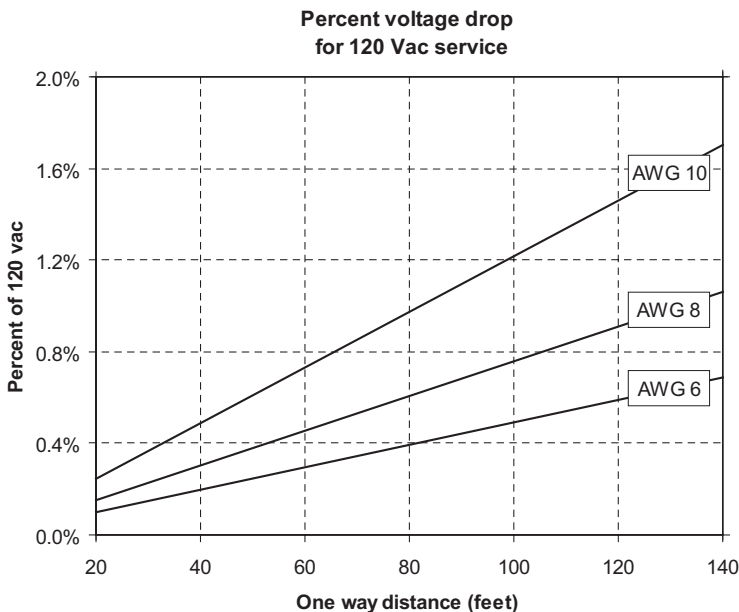

Figure 4-3 Energy Losses in Various Wire Sizes and Wire Lengths

The Sunny Boy 700U is designed to feed 106 V AC to 132 V AC to the utility grid at frequencies from 59.3 Hz to 60.5 Hz. Table 4-1 lists the voltage and frequency limits for the AC connection. See our web site for additional information.

Table 4-1 Voltage and Frequency Limits for the AC Connection

Voltage Range	106 V - 132 V
Frequency Range	59.3 Hz - 60.5 Hz

Connecting the AC Wires

Use the following procedure to connect the AC wires to the Sunny Boy:



WARNING: You must connect the wires that carry the AC voltage from the Sunny Boy to the utility grid in the order described in this procedure. Deviating from this procedure could expose you to hazardous voltages that can cause serious injury and/or death.

1. Turn OFF the main breaker in the main utility breaker box.
2. If you are replacing an existing inverter, disconnect the wires for the AC line you are working with in the breaker box.

3. Install a ½-inch conduit fitting in the Sunny Boy's AC wiring knockout (the knockout farthest to the right on the bottom of the Sunny Boy, as shown in Figure 4-2 on page 4-4). Fasten the fitting on the inside of the Sunny Boy with the nut supplied with the fitting.
4. Install ½-inch conduit between the main breaker box and the Sunny Boy's AC wiring knockout.
5. Pull the AC wires through the conduit from the interior of the breaker box to the interior of the Sunny Boy.



Note: Refer to Figure 4-4 on page 4-8 for steps 7 through 8.



CAUTION: Avoid using wire nuts to join any wires together or to make any connections anywhere in the PV system. Wire nuts are a frequent cause of unreliable connections, resistive connections, and ground faults.

6. Connect the equipment-grounding wire to the terminal labeled PE in the Sunny Boy.
7. Connect the L1 (AC line) wire to the terminal labeled L in the Sunny Boy.
8. Connect the N (AC neutral) wire to the terminal labeled N in the Sunny Boy.
9. Fasten the wires while applying a torque of 35 in-lb.
10. Verify that all connections are correctly wired and properly torqued.

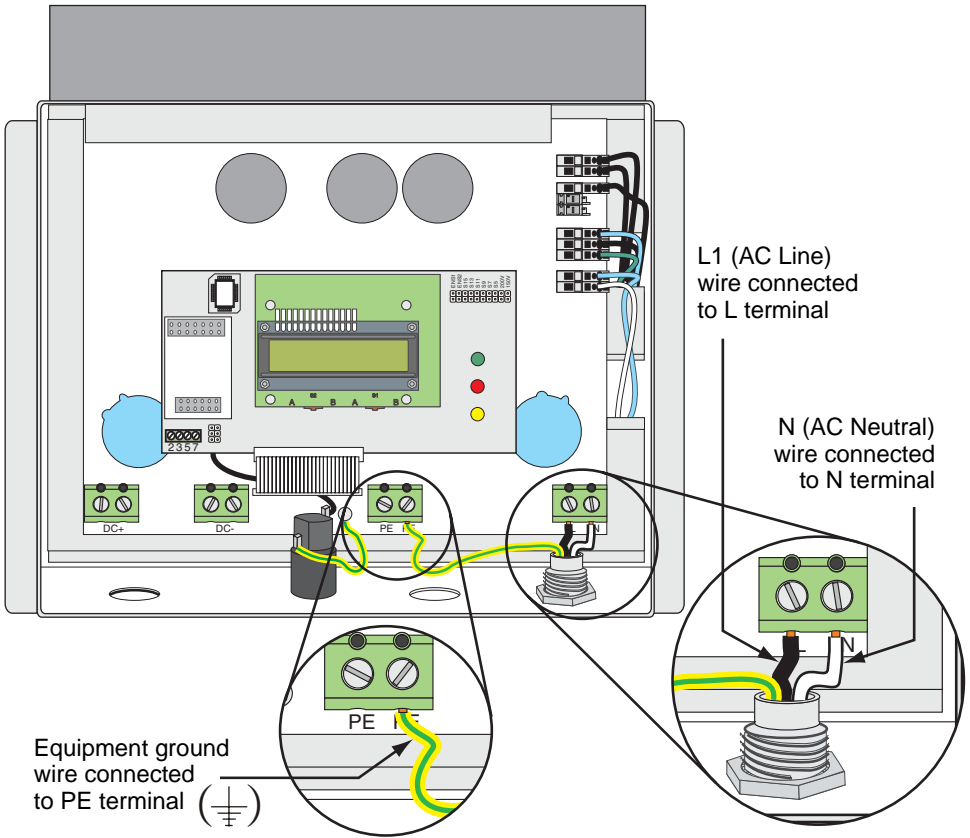

Figure 4-4 AC Connection Terminals

Wiring the DC Input

This subsection provides procedures for configuring the Sunny Boy's DC input-voltage range and for wiring the DC input from the PV array (via the DC disconnect enclosure) to the Sunny Boy. Figure 4-5 shows a simplified wiring diagram of a PV system.

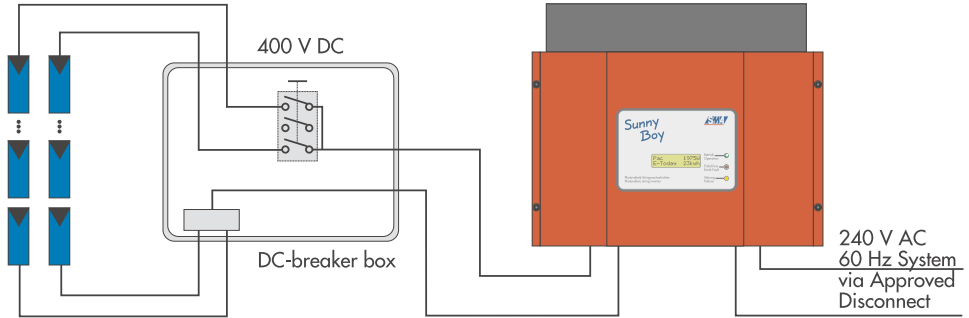

Figure 4-5 Simplified Electrical Wiring Diagram of a PV System

DC Connection Requirements



WARNING: All electrical installations must be done in accordance with all local electrical codes and with the National Electrical Code (NEC), ANSI/NFPA 70. Use #10 AWG (minimum), 90° C (194° F), copper wire for all DC wiring connections to the Sunny Boy. Voltage drop and other considerations may dictate that larger size wires be used.

Configuring the DC Input-Voltage Range

The Sunny Boy 700U is designed for a maximum DC input voltage of 250 V DC. The input voltage range can be configured to match the output of your PV array in three ranges: 125 V DC to 250 V DC (700 W max), 100 V DC to 200 V DC (600 W max), and 75 V DC to 150 V DC (400 W max).

Figure 4-6 (page 4-11) and Table 4-2 (page 4-12) show where to position the range-configuration plug and jumper to configure the Sunny Boy's DC input-voltage range. Table 4-1 (page 4-10) lists the AC-current and power specifications for the Sunny Boy 700U for each of the DC input-voltage range configurations.



CAUTION: *The open-circuit voltage of the connected DC string **must never** exceed the maximum DC input-voltage configured by the DC range-configuration plug and jumper (Figure 4-6 and Table 4-2 on pages 4-11 and 4-12). Applying an open-circuit voltage that does exceed the maximum DC input voltage will cause irreversible damage to the Sunny Boy and void the warranty!*

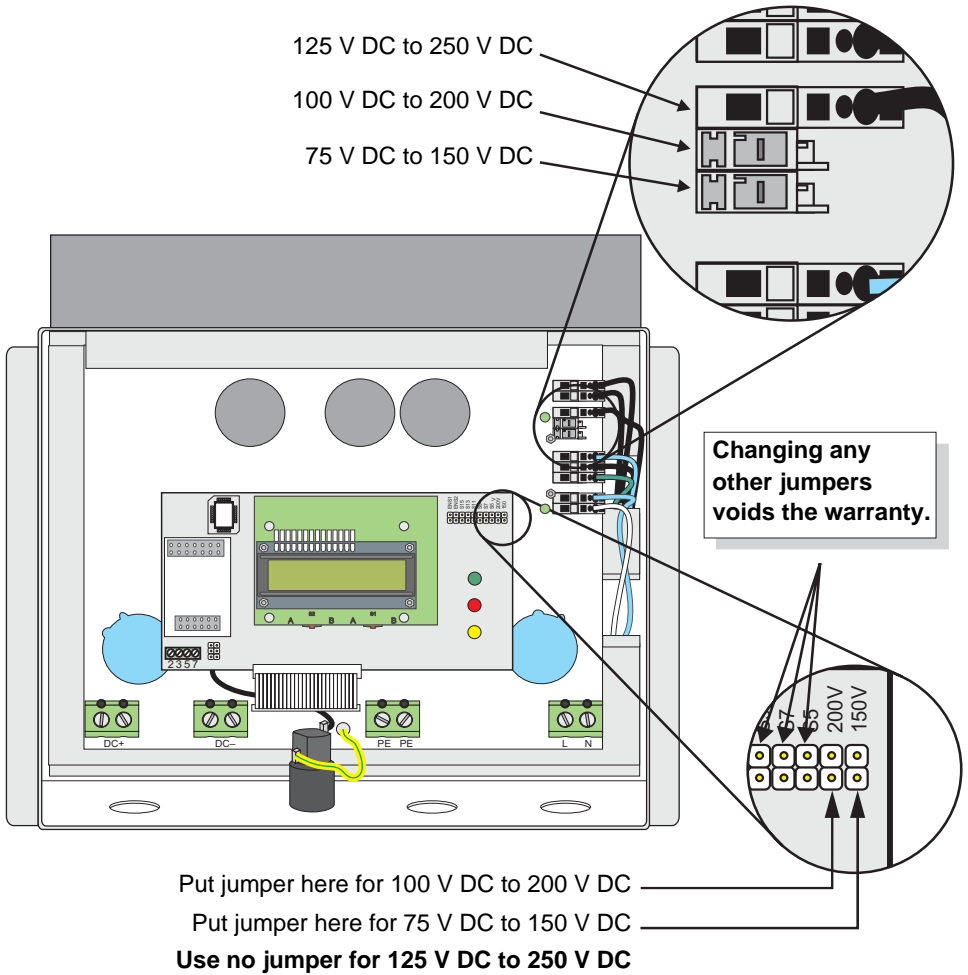

Figure 4-6 Configuring the DC Input-Voltage Range



Note: The Sunny Boy 700U is shipped from the factory with the DC input-voltage range configured for 125 V DC to 250 V DC. **Do not discard the jumper when the Sunny Boy is set for 125 V DC to 250 V DC.** Store the jumper on a single, empty pin in case it is needed later (see Table 4-2).

Table 4-2 DC Input-Voltage Range Configuration

DC Range	DC Range-Configuration Plug	DC Range-Configuration Jumper
125 V DC to 250 V DC (jumper in storage position) (same as no jumper)		
100 V DC to 200 V DC		
75 V DC to 150 V DC		

Table 4-3 Voltage Range Specifications for the Sunny Boy 700U

DC Configuration	Rated AC Current	Maximum AC Current	Maximum AC Power
125 V DC to 250 V DC	5.8 A	6.6 A	700 W
100 V DC to 200 V DC	5.0 A	5.7 A	600 W
75 V DC to 150 V DC	3.8 A	4.3 A	460 W

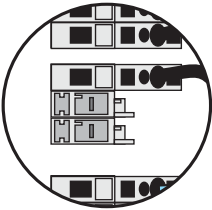
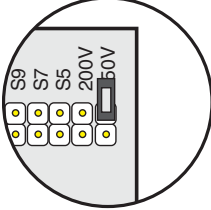
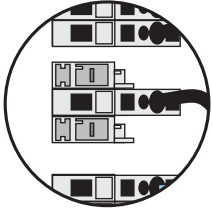
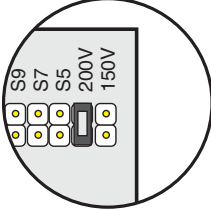
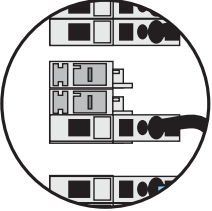
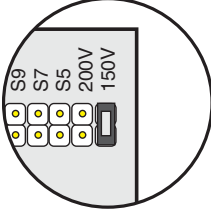

Note: Use the online string-sizing calculator at < www.sma-america.com > to determine the correct string configuration (see Figure 4-7). To navigate to the string-sizing calculator, click “String Sizing” in the menu bar on the right side of the page.

SMA America USA - Microsoft Internet Explorer

Adresse: <http://www.sma-america.com/stringsizing.asp#main>

SMA HOME OF THE SUNNY BOY INVERTER

SOLAR TODAY... ENERGY TOMORROW

Product | **Solar Design Tools** | Downloads | Sunny Community | Contact

String Sizing V 5.11

Further Instructions:
If you are having difficulty with the String Sizing Program, or it is not operating properly, see this [Read Me file](#) for the operating instructions and version history of the String Sizing Program.

If you are having difficulty interpreting the results that you are getting from the String Sizing Program, then please contact your PV panel distributor or re-seller for more information about Sizing PV Arrays for Sunny Boy Inverters. Please do not contact SMA about the results of the Program, unless you are getting an error message.

NOTE:
For an explanation of any particular **entry definition** click on the actual term for a glossary.

Design Options

Please Select an Inverter: SWR 700J 250 (120) | Please Select a PV Manufacturer: Manual Entry | Please Select a PV Module: Manual Entry

Inverter Data

Design Irradiance (W/m²): 1000 | Idc Max: 7 | Vdc Max: 250 | Pac: 700 | Vmpt Max: 250 | Vmpt Min: 123 | Pdcmax: 1000 | Vmin: 123

Module Data

Module Pnom (W): 160 W | Voc (V): 44.2 V | Vmp (V): 35.1 V | Isc (A): 4.80 A | Imp (A): 4.55 A
 Temperature Coefficient of Voltage: -160 mV % | Temperature Coefficient of Current: +0.065 % | Temperature Coefficient of Power: -0.50 %

Mounting Method
Please select the mounting method for the array:
Mounted flat against the roof

Temperature Data
If you do not know the **hottest** and **coldest** ambient temperatures that you should select for your area please enter the 5-digit postal ZIP code of the address of the installation here: [] and then [Click Here](#)

Select the **coldest** record low ambient temperature when sunlight will be on the array: 32° F | Select the **hottest** average high ambient temperature when sunlight will be on the array: 104° F

Results
1 string configurations
5 in series

Get Sizes | Clear | Print Result | Predicted Outputs

* Some derating possible | ** Some derating likely with out adequate air-flow | *** Install a Sunny Breeze Kit to prevent derating

SMA America Inc. - 12438 Loma Rica Drive, Unit C Grass Valley, CA 95945 Phone: (530) 273-4895
 This site was last updated on March 17, 2004
 All content © 2002-2004 SMA-America, Inc., installation photos used with permission

Figure 4-7 Online String-Configuration Calculator at < www.sma-america.com >

Connecting the DC Wires



WARNING: You must connect the wires that carry the DC voltage from the PV array to the Sunny Boy in the order described in the procedure on page 4-15. Deviating from this procedure could expose you to hazardous voltages that can cause serious injury and/or death if you come in contact with them.



WARNING: Completely cover the surface of all PV modules with opaque material before connecting wires to them or working with wires previously connected to them. Allowing any light to reach the PV modules could expose you to hazardous voltages that can cause serious injury and/or death if you come in contact with them.



WARNING: Always turn OFF *all* AC and DC breakers and switches in the PV system and wait a minimum of 5 minutes for the Sunny Boy to completely discharge before connecting any wires to the Sunny Boy or disconnecting any wires from the Sunny Boy. Failure to turn OFF all breakers and switches and waiting 5 minutes for the Sunny Boy to discharge completely could expose you to hazardous voltages that can cause serious injury and/or death if you come in contact with them.



WARNING: When connecting wires to the Sunny Boy, always do so in the following order:

1. Turn *all* switches and breakers OFF.
2. Disconnect *all* AC and DC sources.
3. Connect the Sunny Boy to the utility grid (using an approved disconnect).
4. Connect the PV wires to the DC disconnect enclosure.
5. Connect the DC disconnect wires to the Sunny Boy.
6. Turn all switches and breakers ON.

If it becomes necessary to disconnect the Sunny Boy for repairs or maintenance, perform the steps above in the reverse order beginning with turning all disconnects and breakers OFF and waiting 5 minutes for the Sunny Boy to discharge.



CAUTION: Verify the polarity and the open-circuit voltage from the PV strings before you connect the DC wires to the Sunny Boy. Applying an open-circuit DC-input voltage that exceeds the maximum for the currently configured DC-input-voltage range or has reversed polarity will cause irreversible damage to the Sunny Boy and void the warranty! Always configure the DC-input-voltage range correctly before connecting the DC-input wires from the PV array to the Sunny Boy (see "Configuring the DC Input-Voltage Range" on page 4-10).

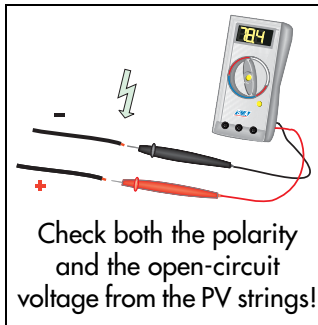

Use the following procedure to connect the DC wires to the Sunny Boy:

1. Verify that the main breaker in the main utility breaker box is OFF.
2. Open the DC disconnect in the DC disconnect enclosure.
3. Install a ½-inch conduit fitting in the Sunny Boy's DC wiring knockout. The DC knockout is the one farthest to the left on the bottom of the Sunny Boy, as shown in Figure 4-2 (page 4-4) and Figure 4-8 (page 4-16). Fasten the fitting on the inside of the Sunny Boy with the nut supplied with the fitting.
4. Install ½-inch conduit between the DC disconnect enclosure and the Sunny Boy's DC wiring knockout.



Note: Refer to Figure 4-8 (page 4-16) for steps 5 through 7.

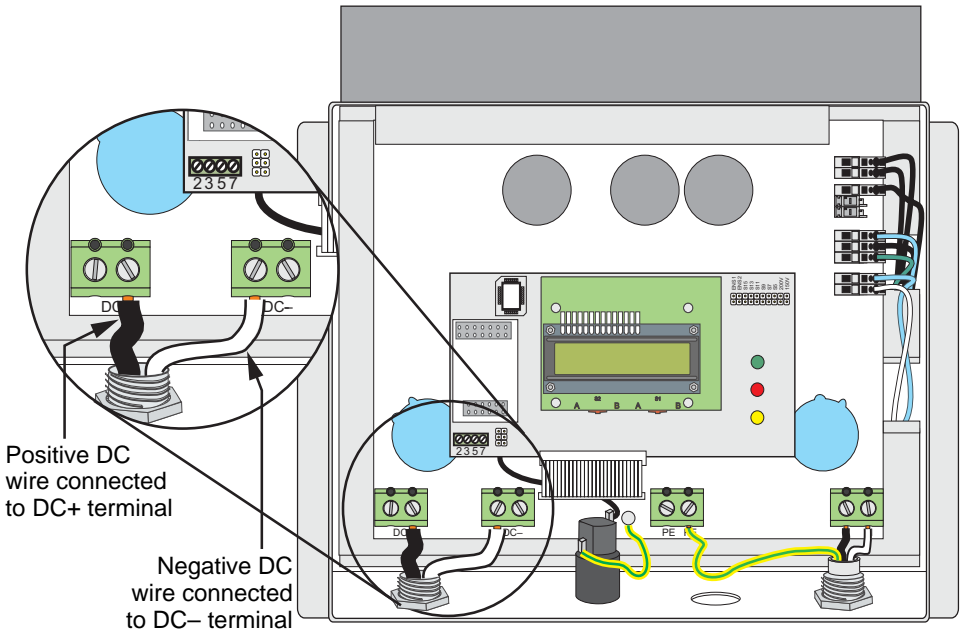

Figure 4-8 DC Connection Terminals

5. Pull the DC wires from the DC disconnect through the conduit into the interior of the Sunny Boy.
6. Connect the positive DC wire to the terminal labeled DC+ in the Sunny Boy.
7. Connect the negative DC wire to the terminal labeled DC- in the Sunny Boy.



Note: The Sunny Boy has provisions for either one or two PV strings. The positive and negative terminal blocks each have two positions, so two pairs of DC-input wires can be connected in parallel.



CAUTION: Avoid using wire nuts to join any wires together or to make any connections anywhere in the PV system. Wire nuts are a frequent cause of unreliable connections, resistive connections, and ground faults.

8. Connect the positive and negative DC wires to the appropriate terminals in the DC disconnect enclosure.
9. Fasten the wires while applying a torque of 35 in-lb.
10. Verify that all connections are correctly wired and properly torqued.

Connecting Communication Cables

Various data-communication options are available for the Sunny Boy 700U. These options are provided in the form of Piggy-Back modules that can be installed and connected either at the time the inverter is installed or at any time thereafter. Refer to the instructions included with the communication module for installation procedures.

The following subsections provide instructions for connecting communication cables of various types between a Sunny Boy with a communication module and a personal computer (PC).

RS-232 Communication

RS-232 is a communication standard for bidirectional transmission of data between a Sunny Boy and a PC (only one Sunny Boy can be connected per RS-232 serial cable).

Requirements for RS-232 Communication:

- The Sunny Boy 700U must be equipped with an RS-232 Piggy-Back communication module.
- A cable no longer than 15 meters (49.2 ft.) with a minimum of two pairs of #24 AWG wires. A cable of this type with a serial connector at one end is available from SMA America.

Connecting an RS-232 Cable

Use the following procedure to install an RS-232 data-communication cable:

1. Run the communication cable from the location of the PC to the Sunny Boy.
2. Determine whether the PC's serial port uses a DB-9 or a DB-25 connector.
3. Attach the appropriate connector to the end of the cable. See Table 4-4 and Figure 4-9 on page 4-18 for the pin assignments for the serial connector. Record the wire color used for each of the pins listed in Table 4-4.
4. Route the other end of the cable into the Sunny Boy through the communication-cable gland on the bottom of the Sunny Boy (see Figure 4-2 on page 4-4).
5. Referring to Table 4-4 and Figure 4-9 on page 4-18 and your record of the wire colors used for each pin from step 3, connect the wires to the communication terminal block in the Sunny Boy.
6. Connect the cable shield to the Sunny Boy's case.



CAUTION: Do not connect the communication cable to the PC or the Interface Converter while the PC is turned on and power is applied to the Sunny Boy.

Table 4-4 RS-232 Pin Assignments

Communication Terminal Block (Sunny Boy)	Signal Name	9-Pin Serial-Port Connector (PC)	25-Pin Serial-Port Connector (PC)
Case	Shield	Case	Case
2	RxD (Output from Sunny Boy)	2	3
3	TxD (Input to Sunny Boy)	3	2
5	GND	5	7

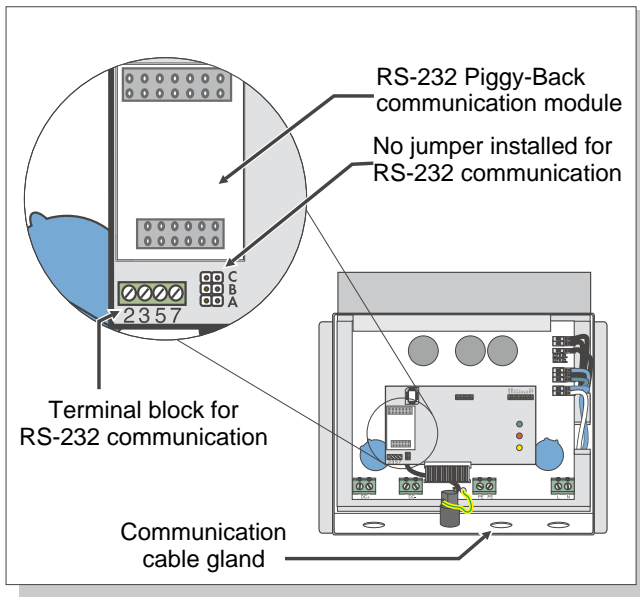
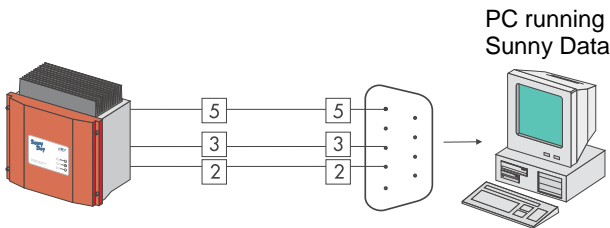

Figure 4-9 Connecting a Sunny Boy to a PC with an RS-232 Cable

RS-485 Communication

RS-485 is a communication standard for bidirectional transmission of data between one or more Sunny Boy inverters and a PC.



Note: All Sunny Boy inverters are capable of RS-485 communication as long as the requirements below are met. You can mix different Sunny Boy models on the RS-485 communication bus.

Requirements for RS-485 Communication:

- The Sunny Boy 700U must be equipped with an RS-485 Piggy-Back communication module.
- A 3 conductor cable no longer than 4000 feet (1200 meters) with a common shield, and a wire size no smaller than 24 AWG. The cable must consist of 2 twisted pairs with a common shield surrounding all 4 wires.

Connecting an RS-485 Cable

Use the following procedure to install an RS-485 data-communication cable:



Note: The following steps describe how to connect one Sunny Boy inverter to an RS-485 bus. For information on connecting more than one inverter to an RS-485 bus, please see “Technical Note: RS-485 Communication” in the Tech Updates section of our web site at www.sma-america.com

1. Connect the three insulated wires of the RS-485 cable to terminals 2, 5, and 7 of the communication terminal block. Record the wire color used for each of the terminals.
2. Connect the shield of the cable to the Sunny Boy’s case.
3. Install a jumper in position A, the bottom set of pins on the communication jumper block, to set it for termination.



Note: The termination of the other end of the RS-485 cable will depend on what type of device you’re connecting to. For detailed information, please see the Tech Updates section of our web site at www.sma-america.com There you will find tech notes on all of the Sunny Boy communication options.

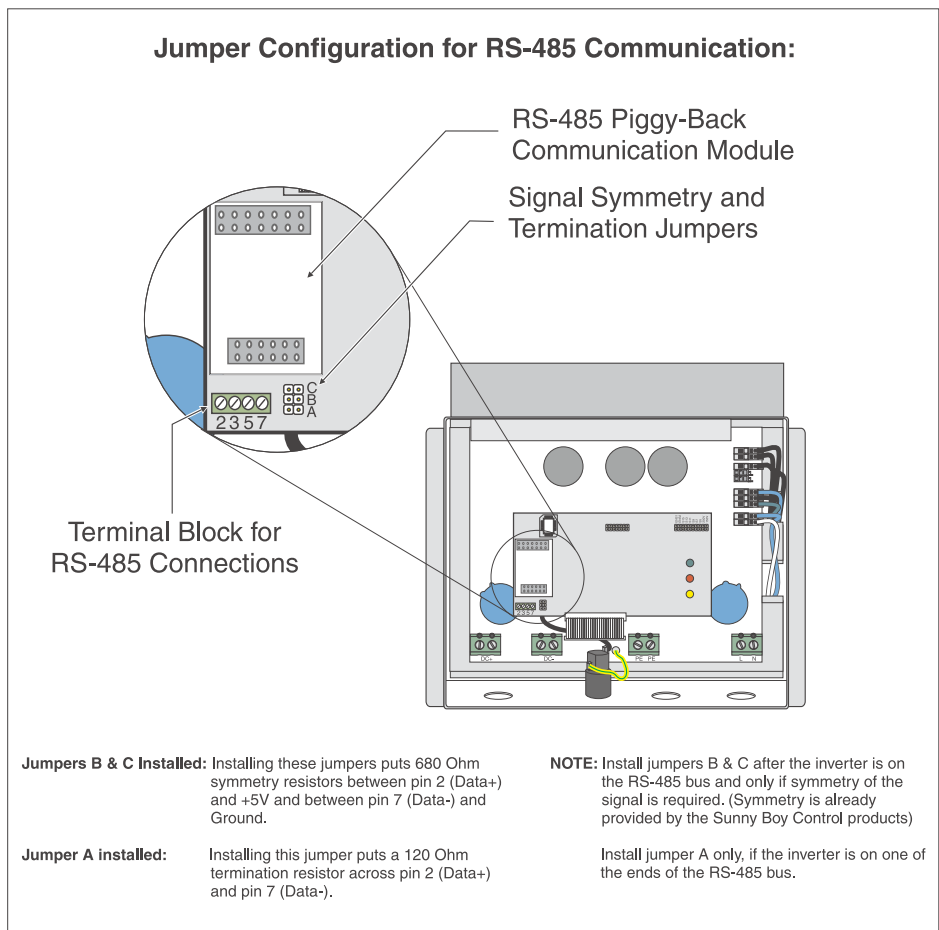

Figure 4-10 Detail of RS-485 Termination and Jumper Settings

RS-485 Pinouts

2 - A (+) (Data+)

7 - B (-) (Data-)

5 - SR (Signal Ref.)

Replacing the Cover

When you have finished connecting the AC-output wires, the DC-input wires, and the communication cables, re-check all your connections to ensure that everything is in the right place and that all connections and knockout fittings are secure and properly torqued. Check all of the knockout fittings on the bottom of the Sunny Boy to ensure that they provide a weather-tight seal.



WARNING: Never apply power to the Sunny Boy with the cover removed.



WARNING: Never install the Sunny Boy during rain or very damp conditions. Because the Sunny Boy is completely sealed, you must be sure no moisture is trapped inside the enclosure when securing the lid.



CAUTION: Be careful not to misplace the screws or the lock washers that attach the cover to the case, as all four screws and lock washers are required to ensure that the cover is grounded properly and is fully sealed to the case. Handle the cover carefully, as even minor damage to the cover could result in an inadequate seal between the cover and the case, thus allowing moisture to enter the case and damage the sensitive electronic components.

Use the following procedure to replace the cover on the Sunny Boy:

1. Check wire dress to ensure that no wires can interfere with proper sealing of the cover and that no pressure will be exerted on the connections when the cover is replaced.
2. Locate the four screws and lock washers you removed to take the cover off the Sunny Boy. Make sure you have all four screws and lock washers, as all of this hardware is necessary to ensure proper grounding and a weather-tight seal.
3. Check the seal on the inside of the cover to ensure it is undamaged and in the correct position.
4. Carefully position the cover on the front of the Sunny Boy so that the four holes in the cover are aligned correctly with the four threaded holes in the case.



Note: Be sure when reinstalling the four screws that the lock washers are installed correctly. The teeth of the washers should face the **LID**.

5. While holding the cover in place, carefully insert the four screws with lock washers through the holes in the cover into the threaded holes in the case and turn them in until they are finger-tight. Be careful not to cross-thread any of the screws.
6. Verify that the cover is in the correct position and that the seal is in place between the case and the cover.
7. Tighten the cover screws fully, and reinspect the seal to ensure that it is in the correct position.

Section 5: Commissioning the Sunny Boy



WARNING: Never apply power to the Sunny Boy with the cover removed. Operating the Sunny Boy with the cover removed and power applied could expose you to hazardous voltages that can cause serious injury and/or death if you come in contact with them.



WARNING: The Sunny Boy has a heat sink on its top surface to help cool the internal components. This heat sink can reach temperatures exceeding 158° F (70° C). To avoid the risk of burns, never touch the Sunny Boy's heat sink while the unit is in operation.



WARNING: When the Sunny Boy is operating, individual parts of the enclosure may reach temperatures of 158° F (70° C) or higher. To prevent fires, ensure that nothing comes in contact with the heat sink and that surrounding materials are sufficiently heat-resistant.



WARNING: Follow the steps in the commissioning procedure in the order they are presented. Deviating from these procedures could expose you to hazardous voltages that can cause serious injury and/or death if you come in contact with them.



CAUTION: Follow the steps in the commissioning procedure in the order they are presented. Deviating from these procedures could cause irreversible damage to the Sunny Boy and void the warranty.

All Sunny Boy inverters have a sophisticated system for detecting ground faults in the PV-array wiring as required by NEC Section 690.5 for PV systems installed on the roofs of dwellings. The PV array normally operates in a grounded configuration, where the array's negative conductor is connected to the grounding system inside the inverter as a part of the ground-fault detection system.

The commissioning procedure in this section allows the installer to verify that the entire PV array and the array conductors are free of inadvertent connections to ground. When the commissioning procedure is completed, internal inverter connections allow the array to operate as a grounded system as required by the NEC.



Note: The commissioning procedure in this section ensures that the PV array is isolated from earth ground, has no unintentional ground faults, and that the GFDI fuse is not defective. No test or measurement equipment is required.

Use the following procedure to commission the Sunny Boy:



Note: This procedure is also presented in flow-chart form in Figure 5-1 on page 5-4.

1. Remove the GFDI fuse from the Sunny Boy. The GFDI fuse extends through the bottom of the Sunny Boy's case (see Figure 4-2 on page 4-4). To remove it, unscrew it from the holder.
2. Connect the grid voltage to the Sunny Boy by turning ON the main 120 V AC circuit breaker in the main utility breaker box.
3. Remove the opaque covering from the PV array.
4. Close the DC disconnect in the DC disconnect enclosure. If sufficient irradiance is present, the PV array produces adequate DC power for the Sunny Boy to operate.

If the PV array and the DC conductors are properly isolated from earth ground, the yellow and red LEDs on the front of the Sunny Boy light, and after approximately 20 seconds, the yellow LED goes dark, but the red LED remains lit. If the Sunny Boy has a display or a communication option installed, and a PC running Sunny Data is connected, a failure message, "GFDI-Fuse open," is displayed.

If both the red and the yellow LEDs remain lit, the PV module has a ground fault. If you have communication equipment, a failure message, "EarthCurrentMax," is displayed on the PC. Open the DC disconnect, locate and correct the problem causing the ground fault, and repeat steps 2 through 4. When the red LED is the only one lit, proceed to step 5.



WARNING: Completely cover the surface of all PV modules with opaque material before working on them or working with wires connected to them. Allowing any light to reach the PV modules could expose you to hazardous voltages that can cause serious injury and/or death if you come in contact with them.

5. Open the DC disconnect in the DC disconnect enclosure, and wait until all of the LEDs on the Sunny Boy have gone off (this should take no more than five minutes).
6. Reinsert the GFDI fuse into the fuse holder on the bottom of the Sunny Boy.
7. Close the DC disconnect in the DC disconnect enclosure.
8. If all of the problems have been resolved, the Sunny Boy switches to normal, fully automatic operation, indicated by the blinking of the green LED. If the red LED remains on, the GFDI fuse is defective and must be replaced.



Note: If the Sunny Boy is not operating as expected after the commissioning procedure is complete, refer to Section 6: Displays and Messages.

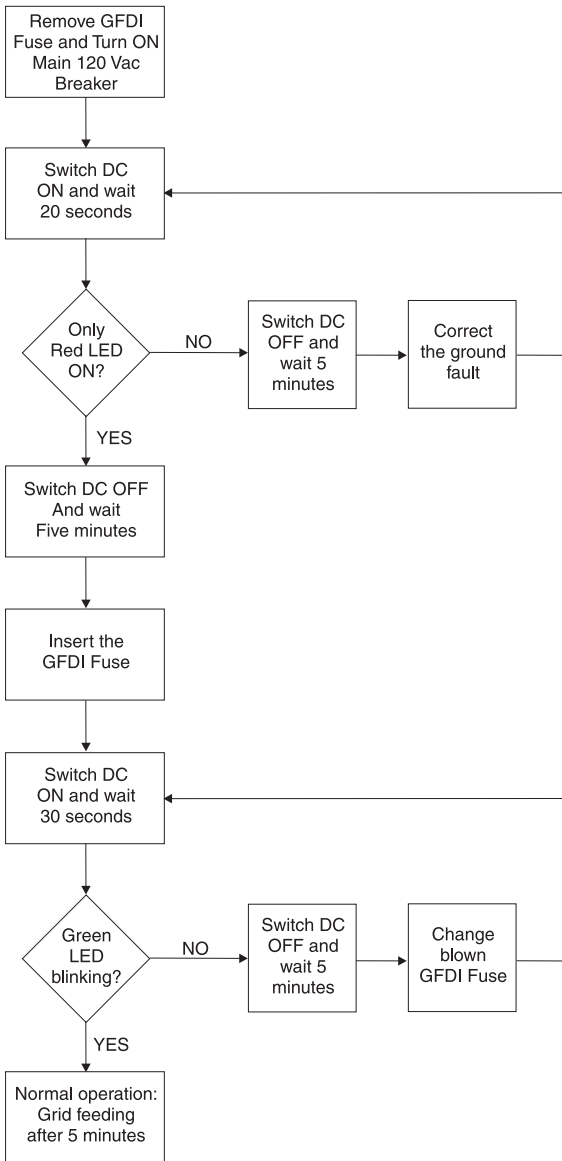

Figure 5-1 Commissioning Flowchart for the Sunny Boy 700U



If the Sunny Boy is not operating as expected after the commissioning procedure is complete, refer to Section 6: “Displays and Messages.”



Note: If there is adequate irradiation, and the resulting input voltage is high enough, the Sunny Boy automatically starts to feed AC power to the household circuits and the grid.



Note: The Sunny Boy operates from the power produced by the PV array and is designed for minimal internal DC-power consumption. The maximum power the Sunny Boy 700U will consume in normal operation is 4W.



Note: Since the Sunny Boy operates from the power produced by the PV array, you must take the power consumed by the Sunny Boy into account when measuring the output voltage of the PV array. When irradiation is at high levels, the relatively negligible amount of power drawn by the Sunny Boy won't be noticeable, but when irradiation is marginal, the Sunny Boy's load will have a noticeable effect on the voltage reading.

Section 6: Displays and Messages

Each Sunny Boy inverter comes equipped with a three LED status indicator. This allows the user to determine the operating mode of the inverter at a glance. The basic definitions of the indicator lights are as follows:

The **green** LED indicates that the inverter is operating and in which mode.

The **red** LED indicates that the GFDI fuse, located in the holder on the underside of the inverter, is defective.

The **yellow** LED indicates that there is a fault of some kind, either inside the inverter itself or somewhere in the system, and that the inverter has ceased operation until the fault is corrected. The different error codes and possible causes are addressed later in this section.

The **red** and **yellow** LEDs combined indicate that the GFDI has detected a ground fault. The ground fault must be located and cleared and the inverter reset manually. The inverter will not restart automatically after detecting a ground fault.



Figure 6-1 The Sunny Boy LED Status Indicator

Operation Indicators

Standby (Night)

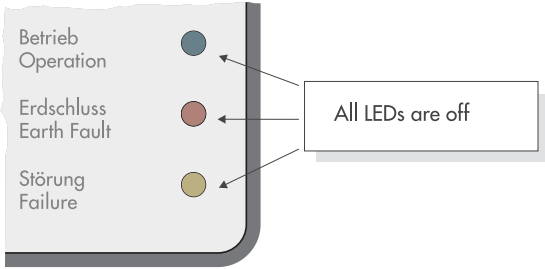

The inverter is in standby mode because the input voltage is too low for operation.

Initialization

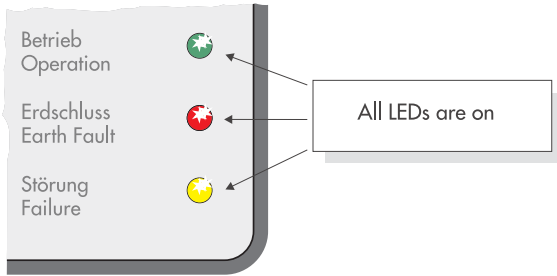

The inverter is initializing. The power from the array is sufficient to operate the control, but not yet powerful enough to begin feeding the grid. Data transmission is not possible during initialization.

Occasionally, during inclement weather or low solar radiation, the LEDs may all turn on at once and then go off again. This indicates that the inverter is trying to initialize but the power available from the array is not sufficient to operate. This is not a malfunction.

Stopped

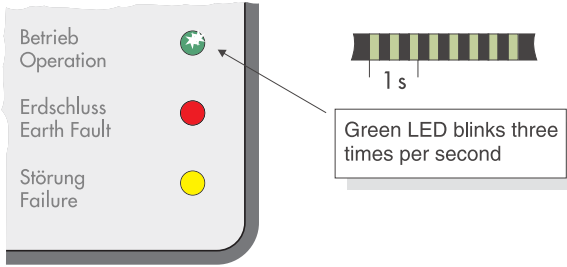

The inverter has stopped operating while there is sufficient power available to calibrate its internal systems. Typically, the calibration lasts less than 10 seconds and then the inverter resumes normal operation.

This status can also be adjusted manually (operating mode „Stop“)

Waiting

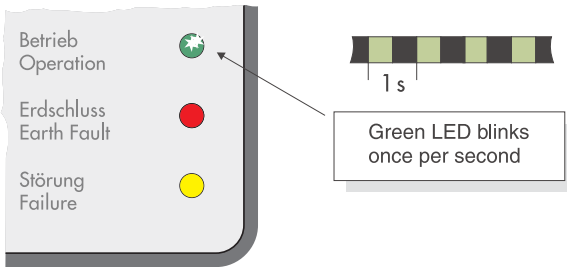

The inverter has determined that there is enough power from the array to operate and is checking the condition of the grid in preparation to connect to it.



Note: If the inverter fails to connect to the utility grid 3 times in a row, it will wait 10 minutes before the next attempt.

Normal Operation

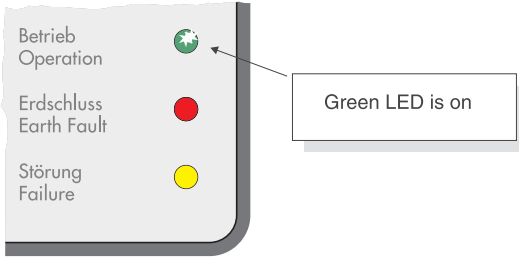

The inverter is feeding the utility grid in either “MPP” or “Constant Voltage” mode.

“MPP” Mode: The Sunny Boy adjusts the voltage from the PV array to match the voltage with the highest output power.

“Constant Voltage” Mode: The voltage from the PV array has been set to a fixed value. This value is set by using the Sunny Boy Control or the Sunny Data software. (The parameter name is “V-Const” or „U-Konst” depending on which software you are using to access the parameters.)

Derating

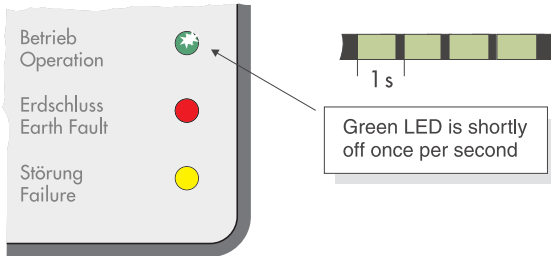

The inverter is feeding power to the utility grid at a derated rate due to excessive heating of the heat sink.

Fault Indicators

Ground Fault

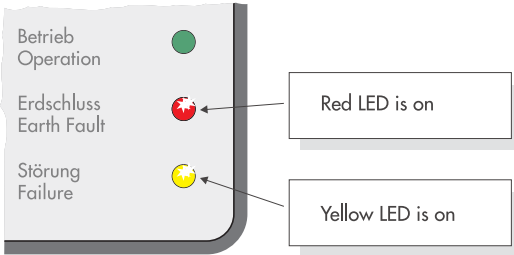

The inverter has detected a ground fault in the PV system and has disconnected from the grid. **The ground fault must be located and cleared and the inverter reset manually.** (The inverter will not restart automatically)

Defective GFDI Fuse

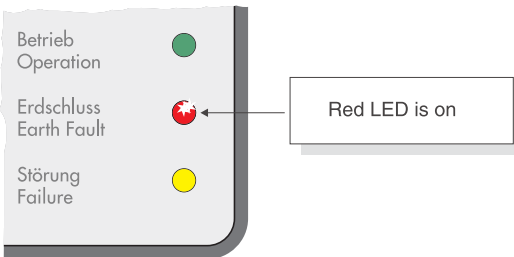

The GFDI fuse located in the fuse holder on the bottom of the inverter is defective. If the fuse has blown due to a ground fault, the fault must be cleared before replacing the fuse.



CAUTION: For continued protection against the risk of fire, replace the GFDI fuse with fuses of the same type and rating only. The recommended type is a **Littelfuse KLKD 1 Amp, 600V AC/DC**

Consistent Fault

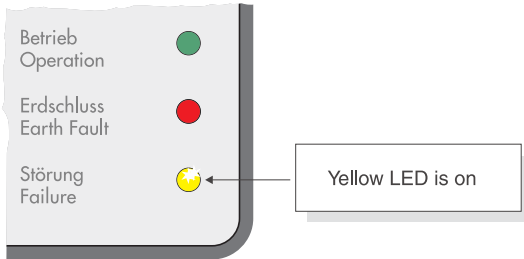

The yellow LED remains lit.

The Sunny Boy has detected a fault with the internal utility monitoring system. When the inverter detects a fault of this kind it will no longer connect to the utility grid. To correct this, the inverter must be serviced by a qualified service technician.

Grid Failure

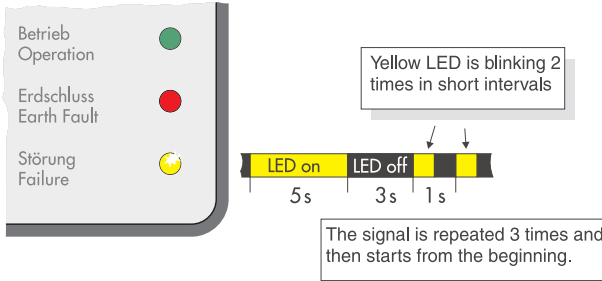

The yellow LED is on for 5 seconds, out for 3 seconds and then blinks twice. The code is repeated 3 times. If the condition remains, the code will continue to be sent.

This code can be caused by any of the following conditions:

- Low Grid Voltage (<Vac Min)
- High Grid Voltage (>Vac Max)
- Low Grid Frequency (< fac Min)
- High Grid Frequency (>fac Max)
- Significant change in grid frequency

Check the condition of the grid by verifying service to other customers or to other equipment. Also inspect the AC disconnect between the Sunny Boy and the grid.



CAUTION: Have the grid connection to the Sunny Boy checked only by a qualified electrician.



WARNING: If troubleshooting methods require that you open the Sunny Boy inverter, do so only after disconnecting all sources of power to the Sunny Boy.

High Grid Impedance

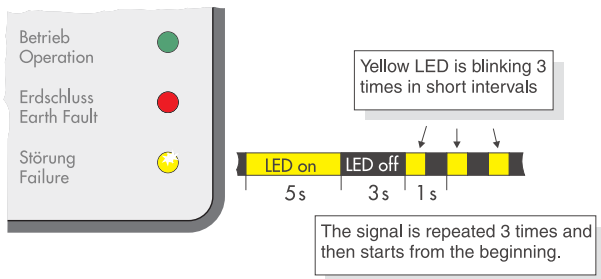

The yellow LED is on for 5 seconds, remains off for 3 seconds and then blinks 3 times. The code is repeated 3 times. If the condition remains the code will continue to be sent.

The inverter has detected a grid impedance value that is too high for safe operation.

If this condition occurs often, the actual grid impedance can be checked using the Sunny Boy Control or Sunny Data. High grid impedance can often be avoided or corrected by increasing the diameter of the AC cables between the grid connection and the inverter.

High Input Voltage

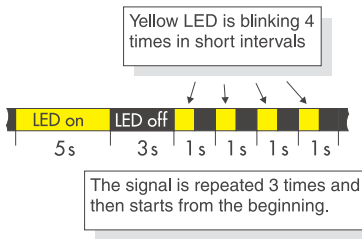
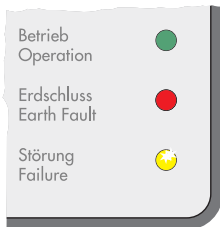

The yellow LED is on for 5 seconds, remains off for 3 seconds and then blinks 4 times. The code is repeated 3 times. If the condition remains the code will continue to be sent.

The inverter has detected an input voltage that is too high for safe operation.



WARNING: Disconnect the PV array from the Sunny Boy immediately! High input voltage can permanently damage the inverter. Have the PV array checked by a qualified technician.

Inverter Fault

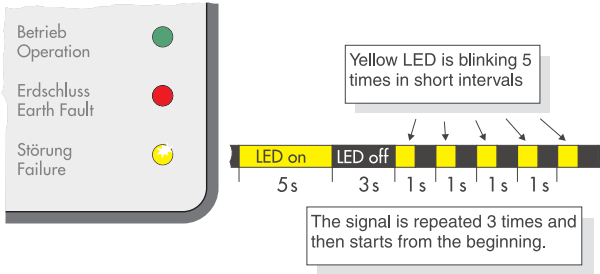

The yellow LED is on for 5 seconds, remains off for 3 seconds and then blinks 5 times. The code is repeated 3 times. If the condition remains the code will continue to be sent.

The inverter has encountered a condition that makes it impossible to return to normal operation and will most likely require servicing.



CAUTION: *The Sunny Boy must be serviced only by a qualified technician.*

Communication Options

Sunny Boy inverters are available from the factory with different communication options installed depending upon your needs. The SB700U series allows for both internal and external metering options to be used simultaneously. These options may also be installed in the field by qualified technicians.

Sunny Display

The Sunny Display is a 2 line LCD display that mounts right in the lid of the inverter. It allows easy access to important system information such as AC power out, PV voltage, daily and total energy yield, hours of operation and inverter status.

Data Transmission

Data that is monitored and collected by the Sunny Boy can be easily transmitted to a remote control unit or PC. This can be accomplished in one of three ways:

Powerline: Data is sent using the electrical wiring in the building as transmission lines.

RS-232: Data from one inverter is sent via RS-232 cable to a remote control unit or PC. Maximum length of cable is 50' (15 m).

RS-485: Data from up to 50 inverters is sent via RS-485 cable to a remote control unit or to a PC. Maximum length of cable is 4000' (1200 m).

Sunny Data

This Windows based application has a user friendly graphical interface that allows you to continuously acquire and evaluate the performance data from your PV system. Each Sunny Boy inverter and the PV strings connected to them can be viewed independently for optimal performance evaluation.

Sunny Boy Control

The Sunny Boy Control products provide continuous monitoring and data acquisition of your PV system. In addition to the original Sunny Boy Control, you can now choose between the economical Sunny Boy Control Light or the full featured Sunny Boy Control Plus.

For more information and assistance in choosing the right data option for your system, please contact SMA America or visit our web site.

Status Messages on the Display

The Sunny Boy 700U is optionally equipped with the „Sunny Display“ LCD in the lid.

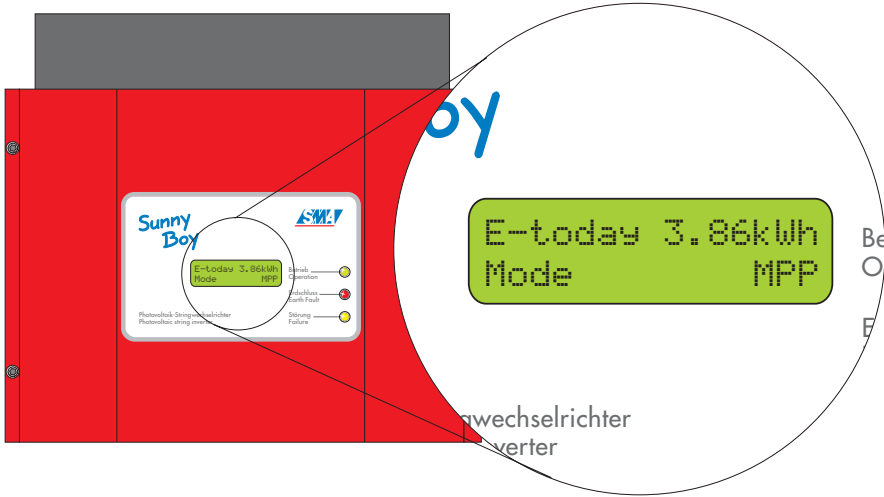

Figure 6-2 Display of the Sunny Boy 700U

Activation of the Background Illumination

The background illumination is activated by slightly knocking on the lid. Knocking once more activates the next message on the display.

The background illumination is automatically deactivated after 2 minutes.

Messages of the Sunny Display During Initialization

The following messages are displayed during initialization of the inverter.

**Sunny Boy 700U
WR70UxxE**

Initialization of the display on the Sunny Boy 700U

The installed firmware versions of the control system (BFR) and the current control processor (SRR) are displayed after 6 seconds.

**BFR Version x.xx
SRR Version x.xx**

Initialization of the display on the Sunny Boy 700U

Messages of the Sunny Display During Operation

The Sunny Display presents all relevant operating data one screen after the other. The images on the side indicate the messages. Each message is displayed for 5 seconds, after all messages have been displayed the display starts from the beginning again.

First the „E-Today“ (total energy produced on this day) is displayed together with the current operating status.

E-today	3.86kWh
Mode	MPP

Energy produced today and current operating status

The message is followed by the current power and the current PV-voltage.

Pac	700W
Vpv	250V

Current AC power and AC voltage

Finally the accumulated yield of the device since installation is displayed together with the total operating hours.

E-total	179.2kWh
h-total	512h

Total energy yield and total operating hours

Messages of the Sunny Display in Case of a Failure

In case of a failure the Sunny Display switches to „Failure“ and the background illumination is activated.

The upper line indicates one of the three following failure types:

- **Disturbance**
A condition is only considered as a Disturbance as long as the reasons for this condition still are present.
- **Error**
A condition is considered as an Error in case the inverter cannot restart without user interaction.

The bottom line indicates the type of a failure for 5 seconds.

**Disturbance
Fac-Bfr**

Indication of a failure
and failure type

Failures that result from a specific value that e.g. exceeds a limiting are specified with the value that caused the failure as well as the current value.

**at: 59.31Hz
present: 59,30Hz**

Display of the value that caused the
failure and the current value

The normal operating data is displayed after 5 seconds.

The display starts from the beginning again in case the failure is still present. For detailed information concerning the failure messages have a look to "Measuring Channels and Messages" (page 6-18).

„Error ROM“ indicates that the Sunny Boy has detected a defective firmware in the EEPROM. Contact SMA in order to remove this failure.

**Error
ROM**

Indication of defective firmware

Indication of DC Overvoltage

A too high voltage on the input (DC) side is indicated with a blinking background illumination and the display shown on the side.

**!PV-Overvoltage!
!DISCONNECT DC !**

Indication of an overvoltage on one of the DC input connectors



WARNING: Disconnect the inverter from the supply voltage immediately, otherwise it can be severely damaged.

Check the input voltage and your module configuration before you reconnect the DC voltage to the inverter again.

Sunny Display Language Selection

The Sunny Display option has the ability to display information in any of four different languages. Setting the language is performed by using a pair of slide switches located along the bottom edge of the display PC board. The language choices are: Spanish, English, French and German. Use the diagram and chart below for setting the display.

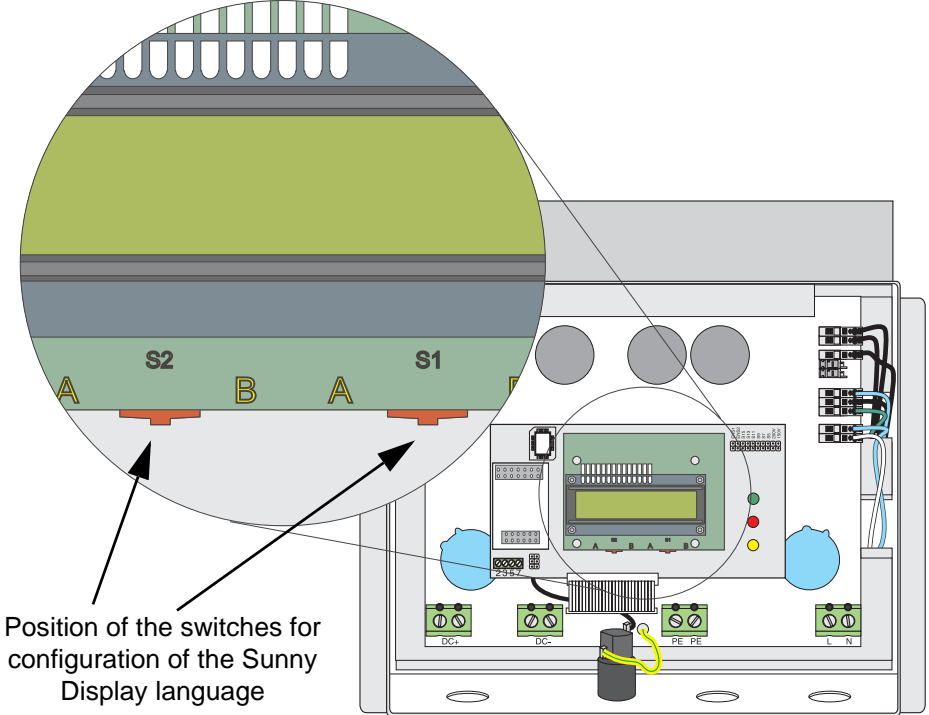

Position of the switches for configuration of the Sunny Display language

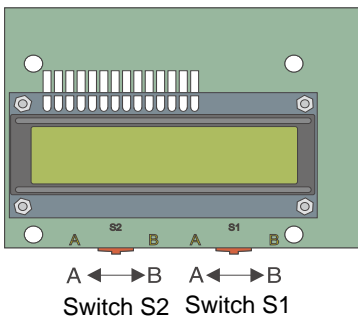

Language	Switch S2	Switch S1
German	B	B
English	B	A
French	A	B
Spanish	A	A

Figure 6-3 Language Selecting Switches for the Sunny Display Option

Measuring Channels and Messages

The communication options support a number of measuring channels and messages from the Sunny Boy inverters.

The following abbreviations are used:

BFR Betriebsführungsrechner (Sequential Control System)

SRR Stromregelungsrechner (Current Control System)

Measuring Channels

Vpv: PV input voltage

Vpv Setpoint: desired input voltage of the Vpv-control

Iac: current to the grid

Vac: grid voltage

Fac: grid frequency

Pac: power fed to grid

Zac: grid impedance

Vpv-PE: PV-voltage to earth

Ipv: current from PV-panels

E-Total (E-total): total energy yield

h-Total (h-total): total operation hours

h-on: h-on indicates how long sufficient DC voltage has been applied to the Sunny Boy and the Sunny Boy has been active including the time it was not able to feed to the utility with respect to too low voltage or operation in stop mode.

Power On: total system start ups

Serial Number: Sunny Boy serial number

Mode: operating mode

Error: description of fault

Mode Messages

Stop:	manual system stop
Offset:	offset calibration of the electronics
Waiting:	grid switching-on conditions are not fulfilled (yet)
Grid monitoring:	checking grid (grid impedance)
MPP-Search:	PV voltage is determined and set
MPP:	Sunny Boy is in MPP mode
V-Const:	Sunny Boy is in constant voltage mode
Derating:	reduction of the grid feeding power
Disturbance:	A condition is only considered a Disturbance for as long as the reasons for this condition still are present.
Error:	A condition is considered an Error whenever the inverter cannot restart without user interaction.

Error messages

In case of an error, the Sunny Boy 700U generates the error code according to the operating mode and the detected error.

Error Code	Description
Vac-Bfr Vac-Srr	<p>The AC grid voltage is exceeding the permissible range. („Bfr“ or „Srr“ is an internal message and is not important for the user.) „Vac“ can also result from a disconnected grid or a disconnected AC cable. The Sunny Boy assumes that the public grid is down and disconnects from the grid in order to avoid islanding.</p> <p>Check the grid voltage and the grid cable connection in the Sunny Boy enclosure. If the grid voltage is out of range due to your local grid conditions contact the utility company and ask, if it is possible to modify the utility conditions. If the grid voltage is within the tolerable range and you still observe the failure message „Vac-Bfr“ or „Vac-Srr“ contact SMA.</p>
Fac-Bfr Fac-Srr	<p>The AC grid frequency is exceeding the permissible range. („Bfr“ or „Srr“ is an internal message and is not important to the user.) The Sunny Boy assumes that the public grid is down and disconnects from the grid in order to avoid islanding.</p> <p>Check the grid frequency and the grid cable connection in the Sunny Boy enclosure. If the grid frequency is out of range due to your local grid conditions contact the utility company and ask, if it is permissible to change the grid monitoring parameters of the inverter. Contact SMA about how to change the grid monitoring parameters of your Sunny Boy. If the grid frequency is within the tolerable range and you still observe the failure message „Fac-Bfr“ or „Fac-Srr“ contact SMA.</p>
Zac-Bfr Zac-Srr	<p>The AC grid impedance is exceeding the permissible range. („Bfr“ or „Srr“ is an internal message and is not important for the user.) The Sunny Boy assumes that the public grid is down and disconnects from the grid in order to avoid islanding.</p> <p>The impedance is the sum of the grids internal impedance and the impedance of the AC cable that connects the inverter to the grid.</p> <p>Check the grid impedance and the grid cable connection in the Sunny Boy enclosure. Use a cable with a higher cross section (=lower impedance) for connection of the inverter to the grid. If the grid impedance is out of range due to your local grid conditions contact the utility company and ask, if it is possible to modify the utility conditions.</p>

Error Code	Description
dZac-Bfr dZac-Srr	<p>The rate of change of the AC grid impedance is exceeding the permissible range. („Bfr“ or „Srr“ is an internal message and is not important for the user.) The Sunny Boy assumes that the public grid is down and disconnects from the grid in order to avoid islanding.</p> <p>If you therefore often observe „dZac-Bfr“ or „dZac-Srr“ consult the utility company and ask, if it is permissible to change the grid monitoring parameters of the inverter. Contact SMA about how to change the grid monitoring parameters of your Sunny Boy.</p>
Imax	Overcurrent on the AC side. This failure code is indicated in case the current to the AC grid exceeds the specification. This may happen in case of harmful interference on the grid. If you observe „F-Imax“ often, check your grid. For assistance contact SMA.
VpvMax	DC input voltage above the tolerable maximum value
MSD-UAC MSD-VAC MSD-FAC MSD-ZAC	Internal measurement comparison error: The Sunny Boy measured values of BFR and SRR are too different from each other.
K1-Close K1-Open	Relay test failed
EEPROM	Transition failure during reading or writing of data EEPROM, the data is not essential for safe operation - this failure does not effect performance.
EEPROM p	Data EEPROM defective, device is set to permanent disable due to the fact that the data loss affects important functions of the inverter. Contact SMA.
OFFSET	Grid monitoring self-test failed.
MSD-Timeout	BFR or SSR controller failure
ROM	The internal test of the Sunny Boy Control system firmware failed. Contact SMA in case you observe this failure often.
Watchdog	Watchdog for operation control triggered
Bfr-Srr	Communication between micro-controllers is failing
Shut-Down	Internal over current continuous
EarthCurMax-Srr	SRR-earth current between PV+ and GND is out of tolerable range
EarthCurMax-Bfr	BFR-earth current between PV+ and GND is out of tolerable range
GFDI Fuse Open	The GFDI-Fuse is defective or open

Sunny Boy 700U Operating Parameters



CAUTION: Any unauthorized modifications of the operating parameters can

- Result in serious injuries or casualties due to altered internal safety precautions within the Sunny Boy
- Void the UL Listing of the Sunny Boy
- Void the warranty of the Sunny Boy
- Void any utility interconnection agreement

Never change the operating parameters without explicit permission and instructions!

Table 6-1 Operating Parameters of the Sunny Boy 700U; 75 - 150 V DC (changeable)

Name	Unit	Range	Default	Description
E-Total E-total	kWh	0 ... 200000		Total energy yield (E_Total) and total operating hours (h_Total) of the inverter. Changing the value can be necessary when a Sunny Boy is exchanged and you wish to match the previously acquired data
h-Total h-total	h	0 ... 200000		
Vconst-Setval	V	75 ... 330	275	PV Setpoint voltage for constant voltage operation. These parameters only are important in case the parameter „Operating Mode“ is set to „V-const“.
Vac-Min	V	90 ... 150	109	Lower (Vac-Min) and upper (Vac-Max) limit of permissible AC voltage (anti-islanding)
Vac-Max	V	90 ... 150	130	
Vpv-Start	V	75 ... 150	95	Voltage where the Sunny Boy starts connecting to the grid.
Fac-Delta-	Hz	0 ... 4.5	0.69	Maximum frequency above (Fac-Delta+) and below (Fac-Delta-) 60 Hz grid frequency before anti-islanding trips.
Fac-Delta+	Hz	0 ... 4.5	0.49	
dFac-MAX	Hz/s	0.005 ... 4.0	0.5	Maximum „rate of change of frequency“ before anti-islanding trips
dZac-Max	mOhm	0 ... 20000	2000	Maximum „rate of change of grid impedance“ before anti-islanding trips
T-Start	s	5 ... 1600	10 / 300	10 Seconds: The time the inverters waits to connect to the grid when turned on. 300 Seconds: The time the inverter waits to reconnect to the grid if a grid disturbance is detected during normal operation.
T-Stop	s	1 ... 1800	2	Time that the Sunny Boy wait until it disconnects from the grid.

Name	Unit	Range	Default	Description
Operating Mode		MPP-Operation V-const Stop	MPP	Operating Mode of the Sunny Boy: MPP-Operation: Maximum Power Point V-const: Constant Voltage Mode (Setpoint defined in „Vconst-Setval“) Stop: Disconnection from utility, no operation
Memory Function		no function default param. reset Op.Data Reset errors	No function	Default param.: Sets all parameters to default. Reset Op.Data: Sets all parameters that are visible in user level to default values. Reset errors: Resets all permanent device disable (dBh) and the failure „EarthCurMax“ occurs. To remove this failure, follow the steps in „Section 5: Commissioning the Sunny Boy“
Default			USA/ UL1741	Used for adjusting the parameters country specific settings
Storage		permanent/ volatile	permanent	permanent: changed parameters are stored in EEPROM and are still available after restarting the Sunny Boys volatile: prevents storing the parameters in EEPROM, i. e. parameters are only saved until next startup
Inst.-Code				The parameters concerning anti-islanding can only be changed after entering the installers password here.

The following parameters appear in parameter list but cannot be modified:

Table 6-2 Operating Parameters of the Sunny Boy 700U; 75 - 150 V DC (fixed)

Name	Unit	Range	Default	Description
Plimit	W	460		Upper limit of AC output power
SMA-SN				Serial Number of the Sunny Boy
Software-BFR				Firmware version of the operation control unit (BFR)
Software-SRR				Firmware version of the current control unit (SRR)
Hardware-BFS				Hardware version of the DC converter control unit (BFS)

Table 6-3 Operating Parameters of the Sunny Boy 700U; 100 - 200 V DC (changeable)

Name	Unit	Range	Default	Description
E-Total E-total	kWh	0 ... 200000		Total energy yield (E_Total) and total operating hours (h_Total) of the inverter. Changing the value can be necessary when a Sunny Boy is exchanged and you wish to match the previously acquired data
h-Total h-total	h	0 ... 200000		
Usoll-Konst	V	100 ... 330	275	PV Setpoint voltage for constant voltage operation. These parameters only are important in case the parameter „Operating Mode“ is set to „V-const“.
Vac-Min	V	90 ... 150	109	Lower (Vac-Min) and upper (Vac-Max) limit of permissible AC voltage (anti-islanding)
Vac-Max	V	90 ... 150	130	
Vpv-Start	V	100 ... 200	125	Voltage where the Sunny Boy starts connecting to the grid.
Fac-Delta-	Hz	0 ... 4.5	0.69	Maximum frequency above (Fac-Delta+) and below (Fac-Delta-) 60 Hz grid frequency before anti-islanding trips.
Fac-Delta+	Hz	0 ... 4.5	0.49	
dFac-MAX	Hz/s	0.005 ... 4.0	0.5	Maximum „rate of change of frequency“ before anti-islanding trips
dZac-Max	mOhm	0 ... 20000	2000	Maximum „rate of change of grid impedance“ before anti-islanding trips
T-Start	s	5 ... 1600	10 / 300	10 Seconds: The time the inverters waits to connect to the grid when turned on. 300 Seconds: The time the inverter waits to reconnect to the grid if a grid disturbance is detected during normal operation.
T-Stop	s	1 ... 1800	2	Time that the Sunny Boy wait until it disconnects from the grid.
Operating Mode		MPP-Operation V-const Stop	MPP	Operating Mode of the Sunny Boy: MPP-Operation: Maximum Power Point V-const: Constant Voltage Mode (Setpoint defined in „Vconst-Setval“) Stop: Disconnection from utility, no operation
Memory function		No function Default param. Reset Op.Data Reset errors	No function	Default param.: Sets all parameters to default. Reset Op.Data: Sets all parameters that are visible in user level to default values. Reset errors: Resets all permanent device disable (dBh) and the failure „EarthCurMax“ occurs. To remove this failure, follow the steps in „Section 5: Commissioning the Sunny Boy“
Default			USA/ UL1741	Used for adjusting the parameters country specific settings
Storage		permanent volatile	permanent	permanent: changed parameters are stored in EEPROM and are still available after restarting the Sunny Boys volatile: prevents storing the parameters in EEPROM, i. e. parameters are only saved until next startup
Inst.-Code				The parameters concerning anti-islanding can only be changed after entering the installers password here.

The following parameters appear in parameter list but cannot be modified:

Table 6-4 Operating Parameters of the Sunny Boy 700U; 100 ... 200 V DC (fixed)

Name	Unit	Range	Default	Description
Plimit	W	600		Upper limit of AC output power
SMA-SN				Serial Number of the Sunny Boy
Software-BFR				Firmware version of the operation control unit (BFR)
Software-SRR				Firmware version of the current control unit (SRR)
Hardware-BFS				Hardware version of the DC converter control unit (BFS)

Table 6-5 Operating Parameters of the Sunny Boy 700U; 125 - 250 V DC (changeable)

Name	Unit	Range	Default	Description
E-Total E-total	kWh	0 ... 200000		Total energy yield (E_Total) and total operating hours (h_Total) of the inverter. Changing the value can be necessary when a Sunny Boy is exchanged and you wish to match the previously acquired data
h-Total h-total	h	0 ... 200000		
Vconst-Setval	V	125 ... 330	275	PV Setpoint voltage for constant voltage operation. These parameters only are important in case the parameter „Operating Mode“ is set to „V-const“.
Vac-Min	V	90 ... 150	109	Lower (Vac-Min) and upper (Vac-Max) limit of permissible AC voltage (anti-islanding)
Vac-Max	V	90 ... 150	130	
Vpv-Start	V	125 ... 250	150	Voltage where the Sunny Boy starts connecting to the grid.
Fac-Delta-	Hz	0 ... 4.5	0.69	Maximum frequency above (Fac-Delta+) and below (Pac-Delta-) 60 Hz grid frequency before anti-islanding trips.
Fac-Delta+	Hz	0 ... 4.5	0.49	
dFac-MAX	Hz/s	0.005 ... 4.0	0.5	Maximum „rate of change of frequency“ before anti-islanding trips
dZac-Max	mOhm	0 ... 20000	2000	Maximum „rate of change of grid impedance“ before anti-islanding trips
T-Start	s	5 ... 1600	10 / 300	10 Seconds: The time the inverters waits to connect to the grid when turned on. 300 Seconds: The time the inverter waits to reconnect to the grid if a grid disturbance is detected during normal operation.
T-Stop	s	1 ... 1800	2	Time that the Sunny Boy wait until it disconnects from the grid.
Operating Mode		MPP-Operation V-const Stop	MPP	Operating Mode of the Sunny Boy: MPP-Operation: Maximum Power Point V-const: Constant Voltage Mode (Setpoint defined in „Vconst-Setval“) Stop: Disconnection from utility, no operation
Memory Function		No function Default param. Reset Op.Data Reset errors	No function	Default param.: Sets all parameters to default. Reset Op.Data: Sets all parameters that are visible in user level to default values. Reset errors: Resets all permanent device disable (dBh) and the failure „EarthCurMax“ occurs. To remove this failure, follow the steps in „Section 5: Commissioning the Sunny Boy“
Default			USA/ UL1741	Used for adjusting the parameters country specific settings
Storage		permanent volatile	permanent	permanent: changed parameters are stored in EEPROM and are still available after restarting the Sunny Boys volatile: prevents storing the parameters in EEPROM, i. e. parameters are only saved until next startup
Inst.-Code				The parameters concerning anti-islanding can only be changed after entering the installers password here.

The following parameters appear in parameter list but cannot be modified:

Operating Parameters of the Sunny Boy 700U; 125 ... 250 V DC (fixed)

Name	Unit	Range	Default	Description
Plimit	W	700		Upper limit of AC output power
SMA-SN				Serial Number of the Sunny Boy
Software-BFR				Firmware version of the operation control unit (BFR)
Software-SRR				Firmware version of the current control unit (SRR)
Hardware-BFS				Hardware version of the DC converter control unit (BFS)

Section 7:

Troubleshooting

Our quality control program assures that each inverter is manufactured to exacting specifications and is thoroughly tested before leaving the factory. If you encounter difficulty with the operation of your inverter, please follow the steps below in an effort to correct the problem.

- Check the blinking code on the lid of the Sunny Boy and compare the code with the blinking codes in chapter 6.
- Check and record the exact "Mode" and "Error" messages on the LCD display or other communication system if installed. Take appropriate action to correct the issue.
- If necessary, check the DC and AC voltages at terminals inside the inverter. Be sure to observe all of the safety precautions listed throughout this manual when doing so, or hire a qualified professional.
- If the system problem persists, contact technical support at: 530.273.4895 Ext.101

In order to better assist you when contacting SMA America, please provide the following information. This information is required **before** removing the inverter from service and prior to making a warranty claim.

Information Regarding the Sunny Boy:

- Serial number
- Model number
- Short description of the problem
- Blinking code (chapter 6)
- What error code is indicated? (Provided a communication option is installed)
- AC line voltage
- DC line voltage
- Check GFDI fuse
- Can you reproduce the failure? If yes, how?
- Has this problem occurred in the past?
- What were the ambient conditions when the problem occurred?

Information Regarding the PV modules:

- Manufacturer and model of the module
- Output power of the module
- Open circuit voltage (Voc) of the module
- Number of modules in each string

If it becomes necessary to send the Sunny Boy back to the manufacturer for service, please ship it in the original box to avoid damage during shipping.

FCC Compliance Information

Sunny Boy Utility Interactive Inverter, Model SB700U

This device complies with Part 15 of the FCC Rules. Operation is subject to the following two conditions:

- (1) This device may not cause harmful interference, and
- (2) this device must accept any interference received, including interference that may cause undesired operation.

NOTE: This equipment has been tested and found to comply with the limits for a Class B digital device, pursuant to Part 15 of the FCC Rules. These limits are designed to provide reasonable protection against harmful interference in a residential installation. This equipment generates, uses, and can radiate radio frequency energy and if not installed and used in accordance with the instructions, may cause harmful interference to radio communications. However, there is no guarantee that interference will not occur in a particular installation. If this equipment does cause harmful interference to radio or television reception, which can be determined by turning the equipment off and on, the user is encouraged to try to correct the interference by one or more of the following measures:

- Reorient or relocate the receiving antenna.
- Increase the separation between the equipment and the receiver.
- Connect the equipment into an outlet on a circuit different from that to which the receiver is connected.
- Consult the dealer or an experienced radio/TV technician for help.
- Caution: Changes or modifications not expressly approved by SMA America, Inc. could void the user's authority to operate this equipment.

Contact SMA America for information

12438-C Loma Rica Drive

Grass Valley, CA 95945, USA

530.273.4895

www.sma-america.com

Sunny Boy SB700U Specifications

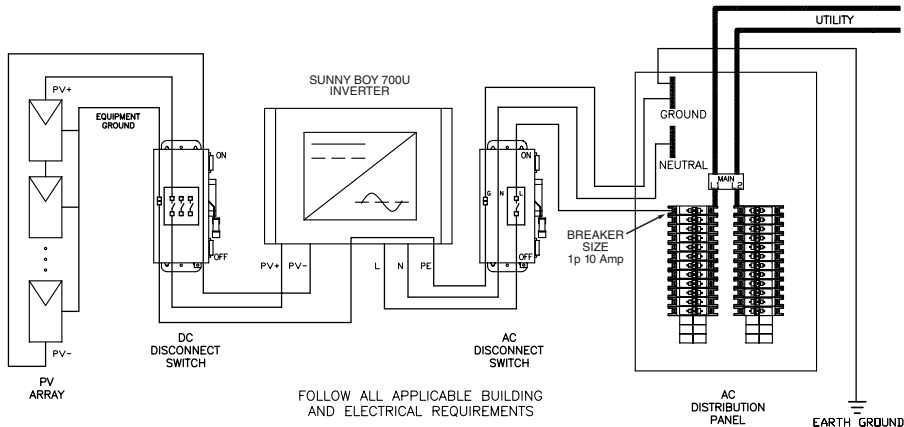

Inverter Technology

AC Input Voltage

AC Input Frequency

Peak Power Tracking Voltage

Minimum DC Input Voltage

Maximum DC Input Voltage

Maximum Array Input Power (DC@STC)

Maximum AC Power Output

Current THD

Power Factor

Peak Inverter Efficiency

Cooling

PV Start Voltage

Maximum AC Output Current

Maximum DC Input Current

DC Voltage Ripple

Power Consumption

Ambient Temperature Rating

Enclosure

Dimensions

Weight

Compliance

Real sine-wave, current source, high frequency PVM

106 - 132 (120 V)

59.3 - 60.5 (60 Hz)

250 / 200 / 150 V DC

125 / 100 / 75 V DC

250 V DC

1000 / 840 / 640 Wp **

700 / 600 / 460 W **

Less than 3 %

Unity

93.6 % / 93.3 % / 92.4 %

Convection cooling (no fan)*

150 / 125 / 95 V DC

4.3 / 5.7 / 6.6 A

7 A

Less than 10 %

0.1 W nighttime, < 4 W standby

65 Degrees C

NEMA 4X (IP65) stainless steel

12.68 W x 12.60 H x 7.09 D inches

(322 W x 320 H x 180 D mm)

35.56 lbs. (16 kg)

United States:

UL1741, E210376, UL 1998, IEEE 519, IEEE 929

ANSI C62.41 D1 & C3, FCC Part 15 A & B

**Jumper settings adjustable

*Optional external fan (Sunny Breeze) available

All specifications subject to change without notice.

SMA America. Inc.

www.sma-america.com

12438-C Loma Rica Drive
Grass Valley, CA 95945
USA
Phone +1 530 273 4895
Fax +1 530 274 7271
www.sma-america.com



Headquarters:
Hannoversche Str. 1-5
34266 Niestetal
Germany
Phone +49 561 9522 0
Fax +49 561 9522 100
www.SMA.de

